

Guardian 1000 Series Hipot Testers Instruction Manual

Form 150665/B3

©QuadTech, Inc., 2000, 2007
5 Clock Tower Place, 210 East
Maynard, Massachusetts, U.S.A. 01754
May 2007

Telephone	978-461-2100
Sales	800-253-1230
Facsimile	978-461-4295
Website	www.quadtech.com

The material in this manual is for informational purposes only and is subject to change, without notice. QuadTech assumes no responsibility for any error or for consequential damages that may result from the misinterpretation of any procedures in this publication.

WARNING

Potentially dangerous voltages may be present on front and rear panel terminals. Follow all warnings in this manual when operating or servicing this instrument. Dangerous levels of energy may be stored in capacitive devices tested by this unit. Always make sure the high voltage indicator is **not** on when connecting or disconnecting the device under test.

Contents

Warranty	7
Specifications	9
Accessories	13
Safety Precautions	15
Condensed Operating Instructions	17

Introduction - Section 1

1.1	Unpacking and Inspection.....	23
1.2	Product Overview	23
1.3	Controls and Indicators.....	24
	1.3.1 Front Panel Controls and Indicators	24
	1.3.2 Rear Panel Controls and Connectors	25
1.4	Installation	26
	1.4.1 Dimensions	26
	1.4.2 Instrument Positioning.....	26
	1.4.3 Power Requirements	26
	1.4.4 Safety Inspection.....	27

Operation - Section 2

2.1	Terms and Conventions	29
2.2	Start-Up.....	33
2.3	Programming Electrical Safety Tests.....	33
2.4	Programming an Open/Short Circuit Check	37
2.5	Programming an AC Hipot Test	39
2.6	Programming a Pause	41
2.7	Programming a DC Hipot Test	43
2.8	Programming an Insulation Resistance Test	45
2.9	Programming a Multi-Step Test.....	47
2.9	PRESET Test Parameters	51
	2.9.1 PASS HOLD	52
	2.9.2 STEP HOLD	52
	2.9.3 AC-V FREQ	52
	2.9.4 GR CONT.	53
	2.9.5 SOFT. AGC	53
	2.9.6 AUTO RANGE	53
	2.9.7 GFI	54
	2.9.8 AFTER FAIL.	54
	2.9.9 SCREEN	54
	2.9.10 SMART KEY	55
	2.9.11 RAMP JUDG	56
	2.9.12 PART NO	56
	2.9.13 LOT NO	57
	2.9.14 SERIAL NO	57

Contents (Continued)

Operation - Section 2 - continued

2.10	Storing a Test Setup	58
2.11	Instrument Offset	60
2.12	GET Cs	62
2.13	Connection to Device Under Test.....	63
2.14	Measurement Procedure.....	64
2.15	MENU Parameters.....	65
2.15.1	MEMORY	66
2.15.1.1	STORE	66
2.15.1.2	RECALL	66
2.15.1.3	DELETE	67
2.15.2	SYSTEM	67
2.15.2.1	CONTRAST	68
2.15.2.2	BEEPER VOLUME	68
2.15.2.3	DC 50V AGC	68
2.15.3	OPTION	69
2.15.3.1	RS232	69
2.15.3.2	GPIB (IEEE-488)	69
2.15.3.3	PRINTER	70
2.15.4	CALIBRATION	71
2.15.5	KEY LOCK	71
2.15.6	CHANGE PASSWORD	72
2.15.7	ERROR LOG	72
2.15.8	PRINT PROGRAM	73
2.15.9	ABOUT	73

Interface - Section 3

3.1	Remote	75
3.2	RS232 Interface	78
3.2.1	Pin Configuration.....	78
3.2.2	RS232 Specifications.....	79
3.2.3	RS232 Commands	79
3.2.4	Sample QuickBASIC Program	80
3.3	IEEE-488 Interface	82
3.3.1	Pin Configuration.....	82
3.3.2	IEEE-488 Interface Codes and Messages	84
3.3.3	IEEE-488 Interface Commands	85
3.3.3.1	IEEE-488 Register Assignments	85
3.3.3.2	IEEE-488 Register Configurations	86
3.3.4	IEEE-488 & SCPI Command Summary.....	88
3.3.5	Error Messages	98
3.3.6	Sample QuickBASIC Programs	99

Contents (Continued)

Interface - Section 3 - continued

3.4	Printer Interface	102
3.5	G16 International Power Strip	104
3.6	S07 Power Entry Adaptor Cable	105
3.7	S03 Corded Product Adaptor	106
3.8	S05 Foot Switch	107
3.9	S08 Gun Probe	108
3.10	Guardian 1050 Ground Bond Tester	109

Service & Calibration - Section 4

4.1	General.....	111
4.2	Instrument Return	111
4.3	Calibration.....	111
4.3.1	Calibration Parameters.....	112
4.3.2	Enable Calibration	113
4.3.3	AC Voltage Calibration	114
4.3.4	DC Voltage Calibration	115
4.3.5	IR Voltage Calibration.....	116
4.3.6	AC Current Calibration.....	117
4.3.7	Real AC Current Calibration	119
4.3.8	DC Current Calibration.....	121
4.3.9	ARC Calibration	123
4.3.10	IR Resistor Calibration	123
4.3.11	Finalize Calibration	125

Warranty



QuadTech warrants that Products are free from defects in material and workmanship and, when properly used, will perform in accordance with QuadTech's applicable published specifications. If within one (1) year after original shipment it is found not to meet this standard, it will be repaired, or at the option of QuadTech, replaced at no charge when returned to a QuadTech service facility.

Changes in the Product not approved by QuadTech shall void this warranty.

QuadTech shall not be liable for any indirect, special or consequential damages, even if notice has been given of the possibility of such damages.

This warranty is in lieu of all other warranties, expressed or implied, including, but not limited to any implied warranty or merchantability of fitness for a particular purpose.

SERVICE POLICY

QuadTech's service policy is to maintain product repair capability for a period of at least five (5) years after original shipment and to make this capability available at the then prevailing schedule of charges.

Specifications

Dielectric Strength

G 1010, 1030, & 1030S

AC Output Voltage:	Range:	0.05 to 5kV AC, in 1V steps
	Regulation:	\pm (1% of setting +5V)
	Frequency:	50/60Hz selectable
Voltage Display:	Accuracy:	\pm (1% of reading +5V)
	Resolution:	1V steps
AC Current Display:	Total & Real current	
	Range:	0.001mA to 30mA AC, in 1 μ A steps
	Accuracy:	\pm (1% of reading + 5 counts) (Total)
	Accuracy:	\pm (5% of reading + 20 counts) (Real)

G 1030 & 1030S

DC Output Voltage:	Range:	0.05 to 6kV DC, in 1V steps
Voltage Display:	Accuracy:	\pm (1% of reading +5V)
	Resolution:	1V steps
DC Current Display:	Range:	0.0001mA to 10mA DC
	3 Ranges:	0.0001mA – 0.3mA; 0.31mA-3mA; 3.1mA-10mA
	Accuracy:	\pm (1% of reading + 5 counts)

Note: AC set over 75 VA, DC set over 22.5 VA the maximum operating time is 60 seconds, the same as rest time. If the period is 1/2 duty (TUV ON), for full rating output, the line input range is +10%, -0%.

Insulation Resistance

G 1030 & 1030S

Insulation Resistance:	Voltage:	50 - 1000V DC in 1V steps
	Accuracy:	\pm (1.5% of reading + 5V)
	Range:	0.1M Ω - 50G Ω (voltage dependent)
	Accuracy:	1M Ω - 1G Ω , \pm (5% + 10counts) \geq 500V
		1G Ω - 10G Ω , \pm (10% + 10counts) \geq 500V
		10G Ω - 50G Ω , \pm (15% + 10counts) \geq 500V
		0.1M Ω - 1G Ω , \pm (10% + 10counts) < 500V

Open/Short Check (OSC)

G1010, G1030 & G1030S

Open/Short:	Detection mode to verify proper connection of DUT
	Voltage: < 100V
	Frequency: 600Hz
	Open: programmable: 10% - 100%, default: 50%
	Short: programmable: 100% - 500%, default: 300%

Specifications (Continued)

General Features

ARC Detection: Detection Current: Range: 1mA – 15mA AC and 10mA DC
 Pulse Width: Minimum: 10 μ s

Ground Fault Interrupt (GFI): Shutdown of current imbalance when $I > 0.5\text{mA}$

Fast Output Cutoff: HV output voltage terminated $<0.4\text{ms}$ after NG (Fail) result

Fast Discharge: $<0.2\text{s}$ (Typical) Discharge of DUT upon termination of HV

Time: Ramp: 0.1sec – 999 sec, OFF
 Test*: 0.3sec – 999 sec, Continuous
 Fall: 0.1sec – 999 sec, OFF
 *Test Time $\leq 60\text{seconds}$ when the voltage and high current limit is $> 75\text{VA}$

Limits: HI/LO programmable during Test Time
 LO can be set to OFF during Hipot Test
 HI can be set to OFF during IR Test

Indication: Pass/fail LEDs, audible alarm

Remote Control: Inputs: START, STOP
 Characteristics: 24V active low, Pulse width $\cong 20\text{ms}$
 Outputs: PASS, FAIL, UNDER TEST
 Characteristics: Dry contact relay, Closed if true
 120V, 100mA max
 Connector: 9 pin male D-series & Terminal Strip

Setup Storage: 99 Memory Locations, 99 Steps, Total of 500 Memory Segments

Standard Interfaces: RS232 Remote I/O

Scanner: 8 Channel HV Internal Scanner (1030S only)

Optional Interfaces: IEEE-488 Printer

Connectors: Front and Rear Connection (1010 & 1030 instruments)
 Front Connection (1030S instrument)
 HV OUTPUT: Custom Banana Socket
 RTN/LOW: Banana Socket

Specifications (Continued)

General Features

Front Panel

Lockout: 11 Digit Password with or without setup recall
LED Display: LOCK

Mechanical: Bench Mount
Dimensions:(w x h x d): 312.5 x 112.5 x 387.5 mm

Weight: 14 kg net, 16.5 kg shipping (1010, 1030)
15 kg net, 17.5 kg shipping (1030S)

Environmental: Operating: 0°C to + 31°C, 80% RH
31°C to + 40°C, RH decreases linearly to 50%
Storage: -10°C to + 60°C, 70% RH
Warm-up Time: 15 minutes

Power:

• 90 - 130V AC	• 50 or 60Hz
• 200 - 250V AC	• 500W max

Supplied:

• Instruction Manual	• Power Cable
• Calibration Certificate	• Test Leads

Ordering Information:	<u>Description</u>	<u>Catalog No.</u>
	AC Hipot Tester	Guardian 1010 (CE-Marked)
	AC/DC/IR Hipot Tester	Guardian 1030 (CE-Marked)
	AC/DC/IR/SC Hipot Tester	Guardian 1030S
	AC/DC/IR/SC Hipot Tester	Guardian 1030S-4 (4-Channel, CE-Marked)

Accessories

Accessories Included

Item	Quantity	QuadTech P/N
AC Power Cord	1	4200-0300
Power Line Fuse 5A 250V SB	1	520108
Power Line Fuse 2.5A 250V SB	1	520134
High Voltage Lead Set, 1m with alligator clips	1	S02
Ground Continuity Lead	1	700100
HV Lead Set (8), unterminated 1030S only	1	G40
Instruction Manual	1	150665
Calibration Certificate	1	N/A

Accessories/Options Available

Item	Quantity	QuadTech P/N
High Voltage Lead Set, high & low, 1m (std. with unit)	1	S02
Corded Product Adaptor, 115V	1	S03
High Voltage Lead Set, high & low, 2m	1	S04
Foot Switch	1	S05
High Voltage Probe	1	S06
Power Entry Adaptor Cable	1	S07
Gun Probe	1	S08
High Voltage Lead, 1m, unterminated	1	S09
High Voltage Lead, 2m, unterminated	1	S10
Gun Probe with Remote Start	1	S11
Load Box, resistive	1	S12
Load Box, custom resistors	1	S14
Pass/Fail Load Box	1	S14-01
Load Box, Power Entry Adapter, Pass/Fail	1	S14-03
Interconnection Cable to Sentry 50 Ground Bond Tester	1	S15
Ground Continuity Lead (standard with unit)	1	700100
International Power Strip	1	G16
Corded Product Adaptor, 240V	1	G25
Printer Interface (replaces IEEE-488)	1	G38
IEEE-488 ('GPIB') Interface	1	G39
HV Lead Set (8) with clips (G1030S)	1	G40
RS-232 Cable (9-pin male to female), 10' length	1	630157
Visual Basic Application Wizard: Up/Download; Log Program	1	G1000-WZD

Safety Precautions

WARNING

The Guardian 1000 Series Hipot Tester can provide an output voltage as high as 6000V DC (5000V AC) to the external device under test (DUT). Although the Guardian unit is designed with full attention to operator safety, serious hazards could occur if the instrument is used improperly and these safety instructions are not followed.

1. The Guardian 1000 unit is designed to be operated with its chassis connected to earth ground. The instrument is shipped with a three-prong power cord to provide this connection to ground. This power cord should only be plugged in to a receptacle that provides earth ground. Serious injury can result if the Guardian 1000 is not connected to earth ground.
2. Tightly connect cable(s) to the **RTN/LOW** terminal. If this is not done, the DUT's casing can be charged to the high voltage test level and serious injury or electrical shock hazards could result if the DUT is touched.
3. Never touch the metal of the High Voltage probe directly. Touch only the insulated parts of the lead(s).
4. Never touch the test leads, test fixture or DUT in any manner (this includes insulation on all wires and clips) when the high voltage is applied and the red **DANGER** light is ON.
5. Before turning on the Guardian unit, make sure there is no device (DUT) or fixture connected to the test leads.
6. After each test, press the **[STOP]** (red) button for safety if there is any concern that HV may still be applied to the output terminals.
7. When the red **DANGER** LED is lit or flashing, NEVER touch the device under test, the lead wires or the output terminals.
8. Before touching the test lead wires or output terminals make sure:
 - a) The red **[STOP]** button has been pressed
 - b) The red **DANGER** LED is OFF.
9. **In the case of an emergency**, turn OFF the POWER switch using a "hot stick" and disconnect the AC power cord from the wall. **DO NOT TOUCH THE Guardian 1000 INSTRUMENT.**
Position the equipment so it is easy to disconnect. Disconnect by means of the power plug or the power connector.
10. If the **DANGER** LED does not go OFF when the **[STOP]** button is pressed, immediately stop using the tester. It is possible that the output voltage is still being delivered regardless of the TEST ON/OFF control signal.
11. When the Guardian 1000 instrument is used in remote control mode, be extremely careful. The High Voltage Output is being turned on and off with an external signal.

While Under Remote Control:

The operator or service personnel must NOT touch the device under test, the test leads or the test probes in any manner when the instrument is under test. Caution must be used to

ensure that the unintentional access to the rear panel remote start control (via gun probe, foot switch or other means) can NOT occur.

Safety Symbols

The product is marked with the following safety symbols.



Product will be marked with this symbol (ISO#3864) when it is necessary for the user to refer to the instruction manual in order to prevent injury or equipment damage.



Product marked with this symbol (IEC417) indicates presence of direct current.



Product will be marked with this symbol (ISO#3864) when voltages in excess of 1000V are present.



Indicates the grounding protect terminal, which is used to prevent electric shock from the leakage on chassis. The ground terminal must connect to earth before using the product.

Warning Procedure can cause hazard to human if the warning is neglected.

Caution Avoid product misuse. It may cause damage to the product itself and the DUT if the caution is neglected.

Note Important information or tips for the procedures and applications.

Warning Signal During Testing

“DANGER – HIGH VOLTAGE TEST IN PROGRESS, UNAUTHORIZED PERSONS KEEP AWAY”

Disposal

Do not dispose of electrical appliances as unsorted municipal separate collection facilities. Contact your local government for information regarding the collection systems available. If electrical appliances are disposed of in landfills or dumps, hazardous substances can leak into the groundwater and get into the food chain, damaging your health and well-being. When replacing old appliances with new one, the retailer is legally obligated to take back your old appliances for disposal.



waste, use

Condensed Operating Instructions

WARNING

High Voltage is applied to the white HV Output Terminal anytime the red **DANGER** LED is ON or flashing. Always make sure the **DANGER** LED is OFF when connecting or disconnecting the device under test (DUT).

General Information

The Guardian 1000 Series Hipot Tester is a measuring instrument for direct readout of hipot output voltage, leakage current and insulation resistance. The voltage applied to the device under test is adjustable from 50V – 5kV AC and 50V to 6kV DC. The trip current limit is programmable from 1uA to 30mA AC in 1uA steps and from 0.1uA to 10mA DC in 0.1uA steps. The output voltage for Insulation Resistance tests is 50V to 1000V DC over a measurement range of 100kΩ to 50GΩ. The Open/Short Circuit (OS) detection mode verifies the proper connection of the DUT by comparing the test reading to a standard capacitance value, Cs. The Pause (PA) mode allows a test sequence to be stopped while leads are changed or another operation is performed.

Start-Up

The Guardian 1000 Series unit can be operated from a power source between 90 and 250VAC at a power line frequency of 50 or 60Hz. The standard Guardian 1000 Series unit is shipped from QuadTech with a 5A fuse in place for AC 90-130V operation. (A 2.5A fuse is included for 200-250V operation). The G1000 unit is shipped with the line voltage selector set for 120V. Refer to paragraph 1.4.3 for instructions on changing the fuse or line voltage selector.

Connect the Guardian 1000 Series unit AC power cord to the source of proper voltage. Operate the G1000 Series instrument with its chassis connected to earth ground. The Guardian 1000 instrument is shipped with a three-prong power cord to provide this connection to ground. This power cord should only be plugged into a receptacle that provides earth ground. Serious injury may result if the G1000 Series instrument is not connected to earth ground.

Press the [POWER] button on the front panel to apply power. To switch the power off, press the [POWER] button again or if measurements are to be made proceed with the Test Parameter Setup in Table COI-1. The G1000 Series instrument should warm up for 15 minutes prior to use.

NOTE

Please read this instruction manual in its entirety before operating this instrument. These condensed operating instructions are not a substitute for all the information provided in the remainder of this manual.

NOTE

Refer to paragraphs 2.3 through 2.10 for a full description of programming test parameters and instruction on how to store the test setup. Test parameters must be set before the G1000 Series instrument can be zeroed.

Condensed Operating Instructions (Continued)

There are numerous menus within the Guardian 1000 Series instruments. Familiarize yourself with these menus prior to programming a test. Figure COI-1 illustrates the STAND BY display and lists the functions that can be accessed by pressing the [F1] through [F4] keys.

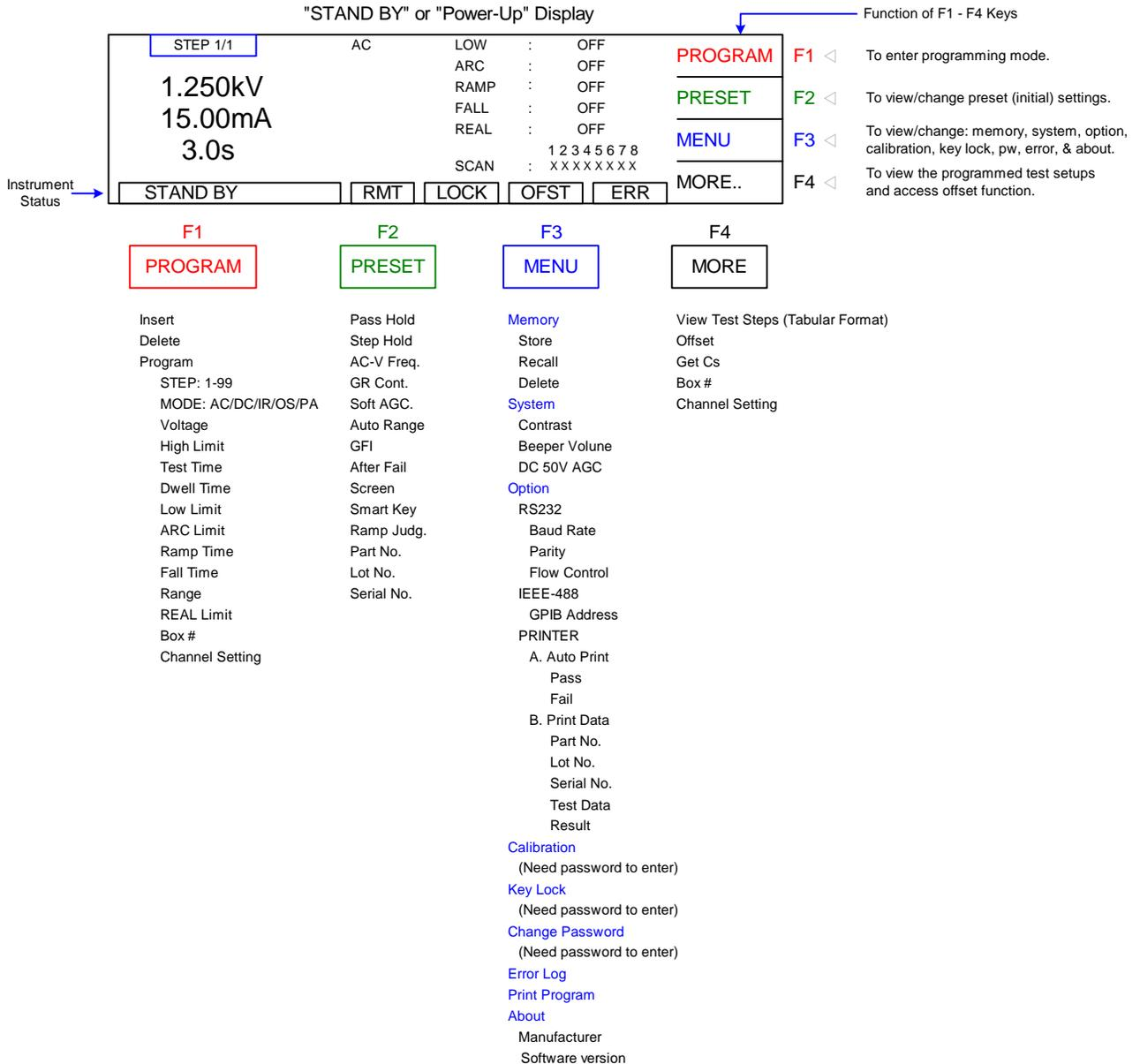

Figure COI-1: G1000 Series Menus

NOTE:

The function of UP/DOWN depends on the menu. When [F3] = ENTER, the UP/DOWN operation changes the highlighted value and the ENTER operation scrolls through the menu selections. When [F3] = SELECT, the UP/DOWN operation scrolls through the menu selections and the SELECT operation chooses (enters into) the highlighted parameter.

Condensed Operating Instructions (Continued)

With the Guardian 1000 Series instrument in “STAND BY” (or power-up display) status, follow the steps in Table COI-1 to program an OS, AC, DC and/or IR test.

<p>"STAND BY" or "Power-Up" Display</p>	<table style="width: 100%; border-collapse: collapse;"> <tr> <td style="width: 20%;">STEP 1/0</td> <td style="width: 20%;">AC</td> <td style="width: 10%;">LOW</td> <td style="width: 10%;">: OFF</td> <td style="width: 10%;"></td> <td style="width: 30%; text-align: right;">PROGRAM</td> </tr> <tr> <td></td> <td></td> <td>ARC</td> <td>: OFF</td> <td></td> <td style="text-align: right;">PRESET</td> </tr> <tr> <td></td> <td></td> <td>RAMP</td> <td>: OFF</td> <td></td> <td style="text-align: right;">MENU</td> </tr> <tr> <td></td> <td></td> <td>FALL</td> <td>: OFF</td> <td></td> <td style="text-align: right;">MORE..</td> </tr> <tr> <td></td> <td></td> <td>REAL</td> <td>: OFF</td> <td></td> <td></td> </tr> <tr> <td></td> <td></td> <td>SCAN</td> <td>: 1 2 3 4 5 6 7 8</td> <td></td> <td></td> </tr> <tr> <td></td> <td></td> <td></td> <td>: X X X X X X X X</td> <td></td> <td></td> </tr> <tr> <td colspan="2" style="text-align: center;">STAND BY</td> <td>RMT</td> <td>LOCK</td> <td>OFST</td> <td>ERR</td> </tr> </table>	STEP 1/0	AC	LOW	: OFF		PROGRAM			ARC	: OFF		PRESET			RAMP	: OFF		MENU			FALL	: OFF		MORE..			REAL	: OFF					SCAN	: 1 2 3 4 5 6 7 8						: X X X X X X X X			STAND BY		RMT	LOCK	OFST	ERR	<p>F1 ◀ To enter program mode.</p> <p>F2 ◀ To view/change preset (initial) test parameters.</p> <p>F3 ◀ To view/change system parameters: memory, system, option, calibration, key lock, password, error, & about.</p> <p>F4 ◀ To view the programmed test setups and access offset function.</p>
STEP 1/0	AC	LOW	: OFF		PROGRAM																																													
		ARC	: OFF		PRESET																																													
		RAMP	: OFF		MENU																																													
		FALL	: OFF		MORE..																																													
		REAL	: OFF																																															
		SCAN	: 1 2 3 4 5 6 7 8																																															
			: X X X X X X X X																																															
STAND BY		RMT	LOCK	OFST	ERR																																													
<p>"PROGRAM" Display</p>	<table style="width: 100%; border-collapse: collapse;"> <tr> <td style="width: 20%;">STEP 1</td> <td style="width: 20%;">AC</td> <td style="width: 10%;">LOW</td> <td style="width: 10%;">: OFF</td> <td style="width: 10%;"></td> <td style="width: 30%; text-align: right;">UP</td> </tr> <tr> <td></td> <td></td> <td>ARC</td> <td>: OFF</td> <td></td> <td style="text-align: right;">MORE..</td> </tr> <tr> <td></td> <td></td> <td>RAMP</td> <td>: OFF</td> <td></td> <td style="text-align: right;">ENTER</td> </tr> <tr> <td></td> <td></td> <td>FALL</td> <td>: OFF</td> <td></td> <td style="text-align: right;">EXIT</td> </tr> <tr> <td></td> <td></td> <td>REAL</td> <td>: OFF</td> <td></td> <td></td> </tr> <tr> <td></td> <td></td> <td>SCAN</td> <td>: 1 2 3 4 5 6 7 8</td> <td></td> <td></td> </tr> <tr> <td></td> <td></td> <td></td> <td>: X X X X X X X X</td> <td></td> <td></td> </tr> <tr> <td colspan="2" style="text-align: center;">PROCESS STEP</td> <td>RMT</td> <td>LOCK</td> <td>OFST</td> <td>ERR</td> </tr> </table>	STEP 1	AC	LOW	: OFF		UP			ARC	: OFF		MORE..			RAMP	: OFF		ENTER			FALL	: OFF		EXIT			REAL	: OFF					SCAN	: 1 2 3 4 5 6 7 8						: X X X X X X X X			PROCESS STEP		RMT	LOCK	OFST	ERR	<p>F1 ◀ To change value in highlighted box.</p> <p>F2 ◀ To delete or insert a test step.</p> <p>F3 ◀ To move highlighted box around display to select parameter to change</p> <p>F4 ◀ To exit program mode.</p>
STEP 1	AC	LOW	: OFF		UP																																													
		ARC	: OFF		MORE..																																													
		RAMP	: OFF		ENTER																																													
		FALL	: OFF		EXIT																																													
		REAL	: OFF																																															
		SCAN	: 1 2 3 4 5 6 7 8																																															
			: X X X X X X X X																																															
PROCESS STEP		RMT	LOCK	OFST	ERR																																													

Figure COI-2: “STAND BY” and PROGRAM Displays

Table COI-1: Test Parameter Setup

	OS	AC Hipot	PA	DC Hipot	IR
1	Test Step	Test Step	Test Step	Test Step	Test Step
	1-99	1-99	1-99	1-99	1-99
2	Test Mode	Test Mode	Test Mode	Test Mode	Test Mode
	OS	AC	PA	DC	IR
3	Open Check	Voltage	Message	Voltage	Voltage
	10-100%	0.05-5kV	13 charc	0.05-6kV	0.05-1kV
4	Short Check	High Limit	Under Test	High Limit	Low Limit
	100-500%	0.001-30mA	On/Off	0.0001-10mA	0.1-50000MΩ
5	CHAN (1-8)	Test Time	Time	Test Time	Test Time
	H, L, X	0, 0.3-999s	0, 0.3-999s	0, 0.3-999s	0, 0.3-999s
6		Low Limit		Dwell Time	High Limit
		0 - 30mA		0-999s	0-50GΩ
7		Arc Limit		Low Limit	Ramp Time
		1-15mA		0 - 10mA	0-999s
8		Ramp Time		Arc Limit	Fall Time
		0-999s		1-10mA	0-999s
9		Fall Time		Ramp Time	Range
		0-999s		0-999s	A, 1-6
10		REAL Limit		Fall Time	CHAN (1-8)
		0 - 30mA		0-999s	H, L, X
11		CHAN (1-8)		CHAN (1-8)	
		H, L, X		H, L, X	

* Unit will make low limit decision at the end of test.

* High Limit Decision is made at start of test time unless judgment wait is set.

Condensed Operating Instructions (Continued)

Offset

After setting your test parameters, zero the Guardian 1000 Series instrument by using the automatic offset. With no device connected, connect the appropriate cable (or other fixture) into the front panel OUTPUT connectors. Refer to paragraph 2.13 cable connections based on test to be performed. Test leads for AC hipot and DC hipot should be OPEN.

Prior to performing the OFFSET function:

1. Allow the instrument to warm up for 15 minutes.
2. Connect the test cables (or fixture) to the front panel OUTPUT and RTN/LOW connectors.
3. Program the test steps.

With the instrument in STAND BY status:

4. Press [F4] = MORE
5. Press [F1] = OFFSET
6. Follow instructions on display: i.e.: connect OPEN across OUTPUT terminal.
7. Press green [START] button.
8. Wait while instrument gets OFFSET value.
9. The OFST block at the bottom of the display is now highlighted (back lit).
10. Press [F4] = MORE to return to STAND BY status.

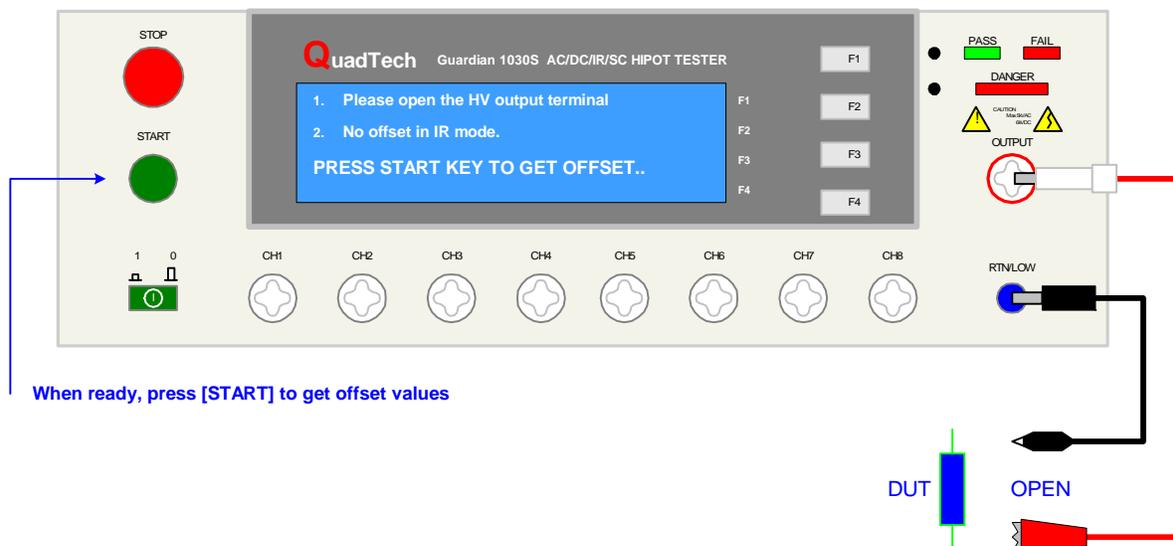

Figure COI-3: Zero/Offset OPEN Configuration

NOTE:

To obtain consistent results, the Offset function must be performed when using OS mode. The Offset function is performed prior to the Get Cs function.

Condensed Operating Instructions (Continued)

Connection to Device under Test (DUT)

Figure COI-4 illustrates the connection of the Guardian 1000 Series unit to a single DUT using the S02 1-meter HV cable set that comes standard with the instrument. The custom white banana plug/red alligator clip is connected between the OUTPUT terminal on the G1000 Series unit and the high side of the device under test. The black banana plug/alligator clip is connected between the RTN/LOW terminal on the G1000 Series unit to the low side of the DUT.

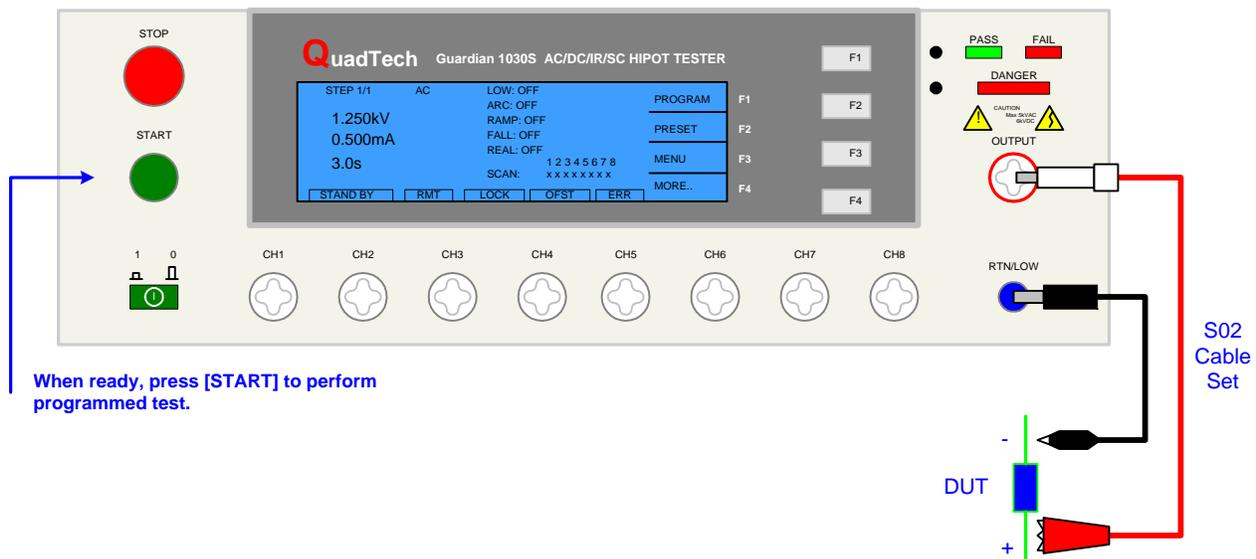

COI-4: Connection to Device under Test

Measurement Mode

1. Turn [POWER] ON.
2. Allow G1000 Series instrument a 15-minute warm up time.
3. Connect S02 Black ground cable to G1000 Series unit RTN/LOW terminal.
4. Connect S02 White/red HV cable to G1000 Series unit OUTPUT terminal.
5. Press [F1] = PROGRAM and enter test parameters. When finished programming, press [F4] = EXIT to return to Stand By status.
6. Press [F4] = MORE to access Offset function. Press [F1] = OFFSET. Follow Offset instructions. When Offset is complete, press [F4] = MORE to return to Stand By.
7. Press [F4] = MORE to access GET Cs function. Press [F2] = GET Cs. Follow Get Cs instructions. When Get Cs is complete press [F4] = MORE to return to Stand By.
8. Connect device under test (DUT) to test leads.
9. Press [START].
10. Record measurement.
11. Press [STOP].

Section 1: Introduction

1.1 Unpacking and Inspection

Inspect the shipping carton before opening. If damaged, contact the carrier agent immediately. Inspect the Guardian 1000 Series instrument for any damage. If the instrument appears damaged or fails to meet specifications notify QuadTech (refer to instruction manual front cover) or its local representative. Retain the original shipping carton and packing material for future use such as returning the instrument for recalibration or service.

1.2 Product Overview

The Guardian 1000 Series is available in three models, the 1010, 1030 and 1030S, all of which provide AC Hipot testing capability. Additionally, the Guardian 1030 & 1030S provide DC Hipot testing and Insulation Resistance testing. The hipot test can be programmed over a voltage range of 0.05 to 5kV AC and 0.05 to 6kV DC with a min/max leakage current detection range of 0.001 to 30mA AC and 0.0001 to 10mA DC. Insulation resistance measurements are possible to 50GΩ at programmable DC test voltages between 50 and 1000V. Each instrument comes standard with ground continuity check, open/short circuit detection mode, pause mode, internal storage of 99 test setups, remote interface with start/stop inputs & pass/fail outputs and an RS232 interface. An optional IEEE-488 Interface or Printer Interface is available for all three instruments. The Guardian 1030S instrument is equipped with a scan interface and 8 HV front panel connectors for multi-point testing. Also available is the Guardian 1030S-4, a 4-channel CE-marked version of the Guardian 1030S.



Figure 1-1: Guardian 1030S AC/DC/IR/SC Hipot Tester

1.3 Controls and Indicators

1.3.1 Front Panel Controls and Indicators

Figure 1-2 illustrates the controls and indicators on the front panel of the Guardian 1000 Series AC/DC/IR Hipot Tester. Table 1-1 identifies them with description and function.

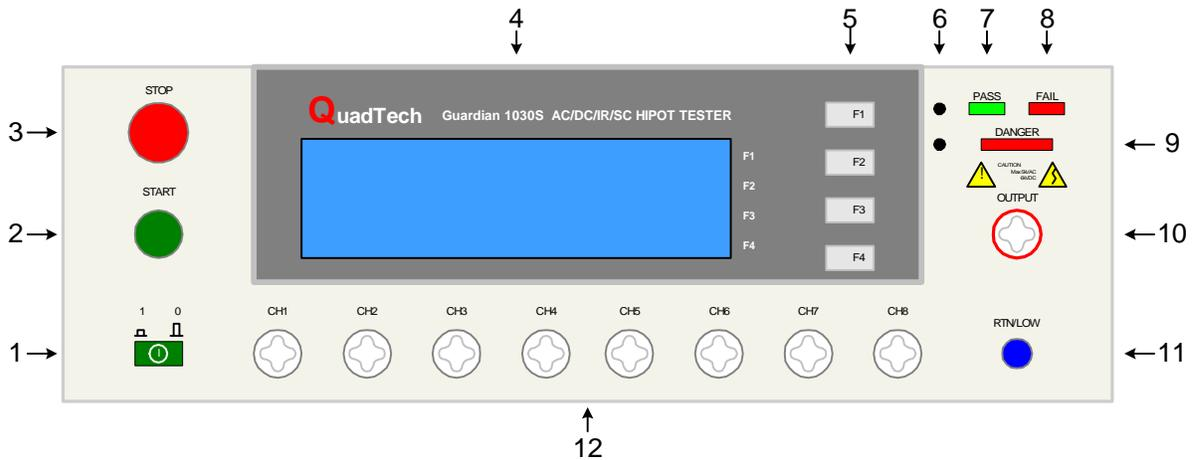

Figure 1-2: Guardian 1030S Front Panel Controls & Indicators

Table 1-1: Guardian 1000 Series Front Panel Controls & Indicators

Reference # Figure 1-2	Name	Type	Function
1	Power	Green Push Button	Apply AC Power: 1=ON, 0=OFF
2	START	Green Push Button	Initiate Test: HV applied to OUTPUT terminal
3	STOP	Red Push Button	Stop Test: HV terminated at OUTPUT terminal
4	Display	LCD	Program Menu, Test Setup, Measurement Results, Memory Contents, Calibration
5	F1, F2, F3 and F4	Gray Push Buttons	Select Instrument Functions Keys perform different functions under different menus. Right side of display shows corresponding key function.
6	CAL UPDATE	Recessed P-B Recessed P-B	Enable/Disable Instrument Calibration Qualified Service Personnel Only
7	PASS	Green LED	When lit, DUT judged as PASS
8	FAIL	Red LED	When lit, DUT judged as FAIL. Output voltage is immediately cut off. Press [STOP] to disable FAIL LED
9	DANGER	Red LED	When lit, high voltage is present at OUTPUT terminals
10	OUTPUT	White Custom Banana Socket	High Voltage (Potential) Terminal
11	RTN/LOW	Blue Banana Socket	RTN: Low voltage reference terminal LOW: Common ground reference terminal
12	CH1-8	8 White Custom Banana Sockets	High Voltage Scan Channels (1030S Only)

1.3.2 Rear Panel Controls and Connectors

Figure 1-3 illustrates the controls and connectors on the rear panel of the Guardian 1000 Series AC/DC/IR Hipot Tester. Table 1-2 identifies them with description and function.

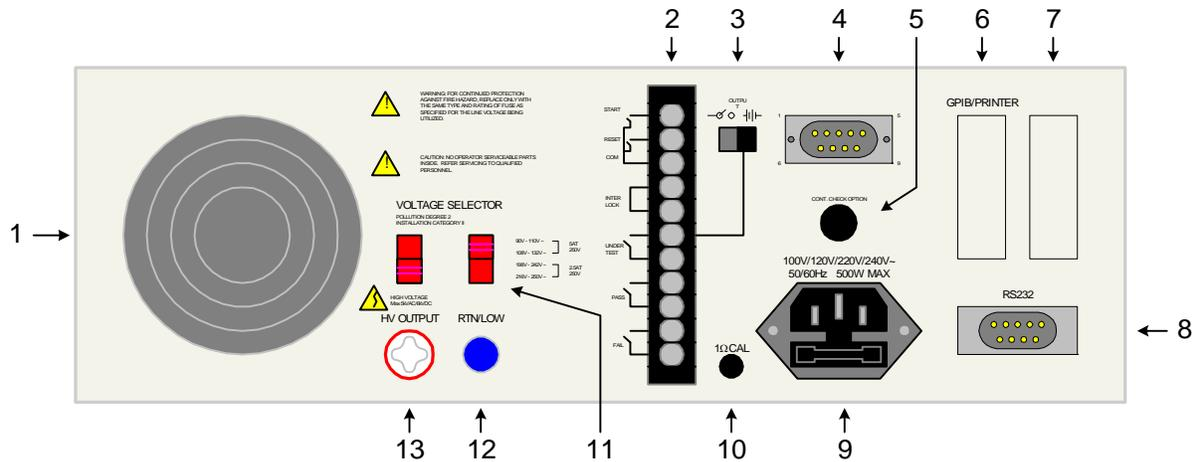

Figure 1-3: Rear Panel Guardian 1000 Series Instrument

Table 1-2: Guardian 1000 Series Rear Panel Controls & Connectors

Reference # Figure 1-3	Name	Type	Function
1	Fan	SF11580AT 115V 50/60Hz 0.10A	Cool Unit: T \geq 50°C = ON, T<45°C = OFF
2	Remote	Black 11-screw Terminal Strip	Remote Connection: Inputs: Start, Stop, Interlock Outputs: Pass, Fail, Under Test
3	Output	Black 2-position Slide Switch	For 24V Output or Relay contact
4	Remote	Silver 9-pin D-Type Connector	Remote Connection: Inputs: Start, Reset, Interlock Outputs: Pass, Fail, Under Test
5	CONT CHK OPT.	Black banana plug	Connection for Ground Continuity Check
6	GPIB/PRINTER	Blue 24-pin	Optional IEEE-488 Interface or Printer connector
7	N/A	N/A	For unspecified use
8	RS232	Silver 9-pin, D-Type	RS232 Interface connector
9	AC Line Input	Black 3-wire inlet module & fuse holder	Connection to AC power source Fuse Drawer: 6.3A 250V or 3.15A 250V (see #11)
10	1ΩCAL	Black hole	Calibration for Continuity, Qualified Personnel Only
11	VOLTAGE SELECTOR	2 Red 2-position Slide Switches	Select Voltage Level corresponding to AC Source 90V – 110V: 5A 250V Slow Blow 110V – 130V: 5A 250V Slow Blow 200V – 240V: 2.5A 250V Slow Blow 220V – 250V: 2.5A 250V Slow Blow
12 *	RTN/LOW	Blue Banana Socket	RTN: Low voltage reference terminal LOW: Common ground reference terminal
13 *	HV OUTPUT	White Custom Banana Socket	Optional rear panel High Voltage (Potential) Terminal

* NOTE: The rear panel HV OUTPUT and RTN/LOW terminals are standard on the 1010 and 1030 units. They are NOT on the 1030S unit.

1.4 Installation

1.4.1 Dimensions

The Guardian 1000 series unit is supplied in a bench configuration, i.e., in a cabinet with resilient feet for placement on a table. Flip feet are provided under the front feet so that the Guardian instrument can be tilted up for convenient operator viewing.

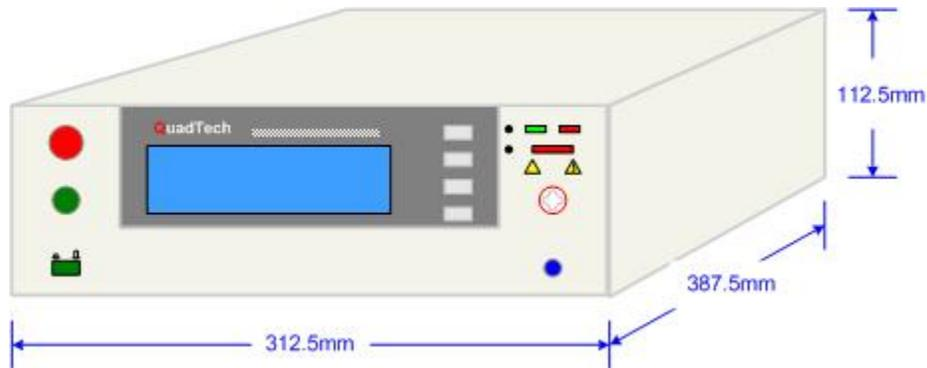

Figure 1-4: Guardian 1000 Series Instrument Dimensions

1.4.2 Instrument Positioning

The Guardian unit contains one (1) graphic display for direct readout of measured parameters. The optimum angle for viewing is slightly down and about 10 degrees either side of center. For bench operation the front flip feet should always be used to angle the instrument up. In bench or rack mount applications the instrument should be positioned with consideration for ample air flow around the rear panel fan ventilation hole. An open space of at least 75mm is recommended behind the rear panel. Testing should be performed on a non-conductive surface. An ESD mat is not a recommended test platform.

1.4.3 Power Requirements

The Guardian can be operated from a power source of 90 to 132V AC or 198 to 250V AC. Power connection is via the rear panel through a standard receptacle. Before connecting the 3-wire power cord between the unit and AC power source, make sure the voltage selection switches on the rear panel (Figure 1-5) are in accordance with the power source being used. For a 90-132V source, use a 5A 250V fuse. For a 198-250V source, use a 2.5A 250V fuse. Always use an outlet that has a properly connected protection ground.

WARNING

MAKE SURE THE UNIT HAS BEEN DISCONNECTED FROM ITS AC POWER SOURCE FOR AT LEAST FIVE MINUTES BEFORE PROCEEDING.

Procedure For Changing A Guardian 1000 Series Fuse

Remove the fuse drawer, by inserting a flat head screwdriver behind the small tab located just below the 3-prong receptacle, and force outward.

Once the fuse drawer has been removed from the instrument snap the fuse from the holder and replace. Make sure the new fuse is of the proper rating. Note that the fuse drawer can also be used to store a spare fuse.

Install the fuse drawer back in the inlet module (fuse down) by pushing in until it locks securely in place.

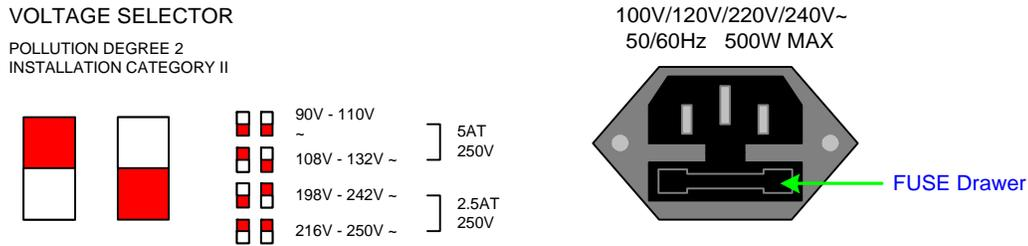

Figure 1-5: Close-Up of G1000 Series Rear Panel

1.4.4 Safety Inspection

Before operating the instrument inspect the power inlet module on the rear of the Guardian to ensure that the properly rated fuse is in place, otherwise damage to the unit is possible. Make sure that the voltage selector switches are set in accordance with the power source in use. Refer to paragraph 1.4.3 and Figure 1-5.

The Guardian instrument is shipped with a standard U.S. power cord, QuadTech P/N 4200-0300 (with Belden SPH-386 socket or equivalent, and a 3-wire plug conforming to IEC 320). Make sure the instrument is only used with these cables (or other approved international cord set) to ensure that the instrument is provided with connection to protective earth ground.

The surrounding environment should be free from excessive dust to prevent contamination of electronic circuits. The surrounding environment should also be free from excessive vibration. Do not expose the Guardian instrument to direct sunlight, extreme temperature or humidity variations, or corrosive chemicals.

Section 2: Operation

2.1 Terms and Conventions

Table 2-1: Measurement Unit Prefixes

<u>Multiple</u>	<u>Scientific</u>	<u>Engineering</u>	<u>Symbol</u>
1000000000000000	10 ¹⁵	Peta	P
1000000000000	10 ¹²	Tera	T
1000000000	10 ⁹	Giga	G
1000000	10 ⁶	Mega	M
1000	10 ³	Kilo	k
.001	10 ⁻³	milli	m
.000001	10 ⁻⁶	micro	u
.000000001	10 ⁻⁹	nano	n
.000000000001	10 ⁻¹²	pico	p
.000000000000001	10 ⁻¹⁵	femto	f

ARcing: Sparking or ‘flashing over’ caused by a breakdown of electrical insulation.

Current:

AC: Alternating Current. AC is an electrical current that has one polarity during part of the cycle and the opposing polarity during the other part of the cycle. Residential electricity is AC.

DC: Direct Current. Non-reversing polarity. The movement of charge is in one direction. Used to describe both current and voltage. Batteries supply direct current (DC).

Charging Current: An insulated product exhibits the basic characteristics of a capacitor. Application of a voltage across the insulation causes a current to flow as the capacitor charges. This current instantaneously rises to a high value as voltage is applied then exponentially decays to zero as the DUT becomes fully charged. Charging current decays to zero much faster than dielectric absorption.

Dielectric Absorption:	The physical phenomenon in which insulation appears to absorb and retain an electrical charge slowly over time. Apply a voltage to a capacitor for an extended period of time. Then quickly discharge it to zero voltage. Leave the capacitor open circuited for a period of time then connect a voltmeter to it and measure the residual voltage. The residual voltage is caused by the dielectric absorption of the capacitor.
Dielectric Strength:	The ratio between the voltage at which breakdown of the insulating material occurs and the distance between the two points subject to the applied voltage.
Dielectric Withstand Test:	This is the most common electrical safety test performed. A high voltage (either AC or DC) is applied to determine if a breakdown will occur in the insulation of the DUT. Dielectric Withstand is also referred to as a hipot (high potential) test.
Discharge:	The act of draining off an electrical charge to ground. Devices that retain charge should be discharged after an IR test or DC hipot test.
DUT:	Device Under Test. (i.e. the product being tested).
Frequency:	The rate at which current or voltage reverses polarity and then back again completing a full cycle, measured in Hertz (Hz) or cycles/second. AC Line Frequency = 50/60 Hz.
Ground:	
Ground:	The base reference from which voltages are measured, nominally the same potential as the earth. Ground is also the side of a circuit that is at the same potential as the base reference.
Ground Bond Test:	Test to verify that all conductive parts of a product that are exposed to user contact are connected to the power line ground. The ground bond test verifies the integrity of the ground connection using a high current AC signal with current level as high as 30Amps. Ground bond provides a better simulation of how a product will perform under an actual fault condition.
Ground Continuity:	Test to verify that all conductive parts of a product that are exposed to user contact are connected to the power line ground. GC Test normally performed with a low current DC signal that checks to ensure the ground connection has a resistance of $<1\Omega$.

Insulation Resistance: Measures the total resistance between any two points separated by electrical insulation. The IR test determines how effective the dielectric (insulation) is in resisting the flow of electrical current.

Interface:

IEEE-488: General Purpose Interface Bus (GPIB). GPIB is an industry standard definition of a Parallel bus connection for the purpose of communicating data between devices.

RS232: An industry standard definition for a Serial line communication link or port.

Scanner: An electronic device designed to switch or matrix signals.

Leakage Current (LC):

Leakage Current: The residual flow of current that flows through the insulation after a high voltage has been applied for a period of time. The leakage current is equal to the applied voltage divided by the insulation resistance. Leakage current is the main measured value for AC hipot and DC hipot.

Applied Part LC Test: A line leakage current test that measures the current that would flow from, to or between applied parts such as sensor and patient leads. This test is the most complicated and time-consuming line leakage test.

Earth LC Test: The most important and most common of the line leakage tests. Earth leakage current is basically the current flowing back through the ground conductor on the power cord. It is measured by opening the ground conductor, inserting a circuit with the simulated impedance of the human body then measuring the voltage across part of the circuit with a true RMS voltmeter.

Enclosure LC Test: A line leakage test that measures the current that flows through the human body if the body had touched the enclosure of the DUT.

Line LC Test: A line voltage leakage current test simulates the effect of a person touching exposed metal parts of a product and detects whether or not the leakage current that flows through the person's body remains below a safe level. Apply power to the product being tested, then measure the leakage current from any exposed metal on the chassis of the product under a fault conditions such as "no ground". A special circuit is used to simulate the impedance of the human body.

Limits:

High Limit:

The high limit is the upper value for a test to be considered a pass. If the measured value is higher than the high limit the test is considered a fail. In hipot, leakage current and ground bond test modes a high limit is required.

Low Limit:

The low limit is the lower value for a test to be considered a pass. If the measured value is lower than the low limit the test is considered a fail. In insulation resistance test mode a low limit is required. In an AC or DC Hipot test, the low limit FAIL decision occurs at the end of the programmed test time.

Mode:

The test which is to be performed such as AC Hipot (WAC), DC Hipot (WDC), Insulation Resistance (IR), Ground Bond (GR) or Leakage Current (LC).

RAMPing:

The gradual increase or decrease of voltage or current over a period of time (step).

Step:

The Guardian 1000 Series instrument can perform up to 10 tests in a sequence. The step number indicates in which order the tests will be performed. For example if step 1 is a ground bond test, step 2 an AC hipot and step 3 an insulation resistance measurement then when a test is started the Guardian will perform a ground bond test followed by an AC hipot then an insulation resistance measurement.

Test Current:

Real Current:

The real current test is a measure of the resistive current component of the device under test. The resistive component is attributed to the resistance of the device's insulation.

Total Current:

The total current test is a measure of the resistive and reactive current components of the device under test. The reactive component is attributed to the capacitive or inductive components of the circuit

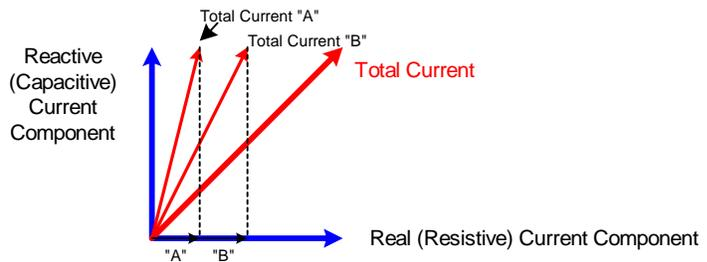

$$\frac{\text{Real "B"}}{\text{Real "A"}} = \frac{200}{100} > 100\% \quad \frac{\text{Total "B"}}{\text{Total "A"}} = \frac{101}{100} > 1\% \quad \frac{\text{Reactive "B"}}{\text{Reactive "A"}} = \frac{100}{100} > 0\%$$

2.2 Startup

Check to make sure the Red Voltage Selector Switches on the rear panel agree with the power source available. Depending on the power source the switch positions should be in the up or down positions as shown in Figure 1-5 (Close-Up of G1000 Series Rear Panel).

WARNING

NEVER TOUCH THE TEST LEADS IN ANY MANNER (this includes insulation on all wires and clips) when HIGH VOLTAGE IS APPLIED and red **DANGER** LED is ON.

USE ALL PRECAUTIONS NECESSARY TO AVOID TOUCHING THE DEVICE UNDER TEST WHEN THE RED **DANGER** LED IS ON OR FLASHING.

Connect the instrument power cord to the source of proper voltage. **The instrument is to be used only with three-wire grounded outlets.**

Power is applied to the Guardian 1000 Series instrument by pressing the green [POWER] switch on the front panel to the ON (1 position). The Guardian 1000 Series unit should warm up for a period of at least 15 minutes prior to use.

WARNING

DO NOT TURN INSTRUMENT POWER ON OR OFF WITH TEST DEVICES CONNECTED.

2.3 Programming Electrical Safety Tests

The Guardian 1000 Series instrument is capable of performing the tests listed in Table 2-2. A single-step test can be performed on a device and is programmed as described in paragraphs 2.4 – 2.8. When the device under test requires a multi-step test the order of test precedence is important. A Pause cannot be programmed as the last step of a sequence. Refer to paragraph 2.9 for programming a multi-step test.

Table 2-2: Guardian 1000 Series Electrical Safety Tests

Test	Software Designation	Programming Paragraph	G1000 Series Instrument
Open/Short Circuit	OS	2.4	1010, 1030, 1030S
AC Hipot	AC	2.5	1010, 1030, 1030S
Pause	PA	2.6	1010, 1030, 1030S
DC Hipot	DC	2.7	1030, 1030S
Insulation Resistance	IR	2.8	1030, 1030S
Multi-Step		2.9	1010, 1030, 1030S

A scan test is programmed in the last step of an OS, AC, DC and/or IR test setup. The Guardian 1030S is equipped with an internal 8 channel HV scanner. The Guardian 1030S-4 is a 4-channel CE-Marked version of the Guardian 1030S. The rear panel scan interface is standard on the Guardian 1030S (and 1030S-4). An external scanner can be used with the Guardian 1000 Series instrument. Refer to paragraph 3.5 for further description of the scan interface.

Function keys of the STAND BY Display

The function keys on the right hand side of the display allow the operator to access the numerous menus imbedded within the Guardian 1000 Series instrument software. Familiarize yourself with these menus prior to programming a test. Figure 2-1 illustrates the STAND BY display and lists the functions that can be accessed by pressing the [F1] through [F4] keys.

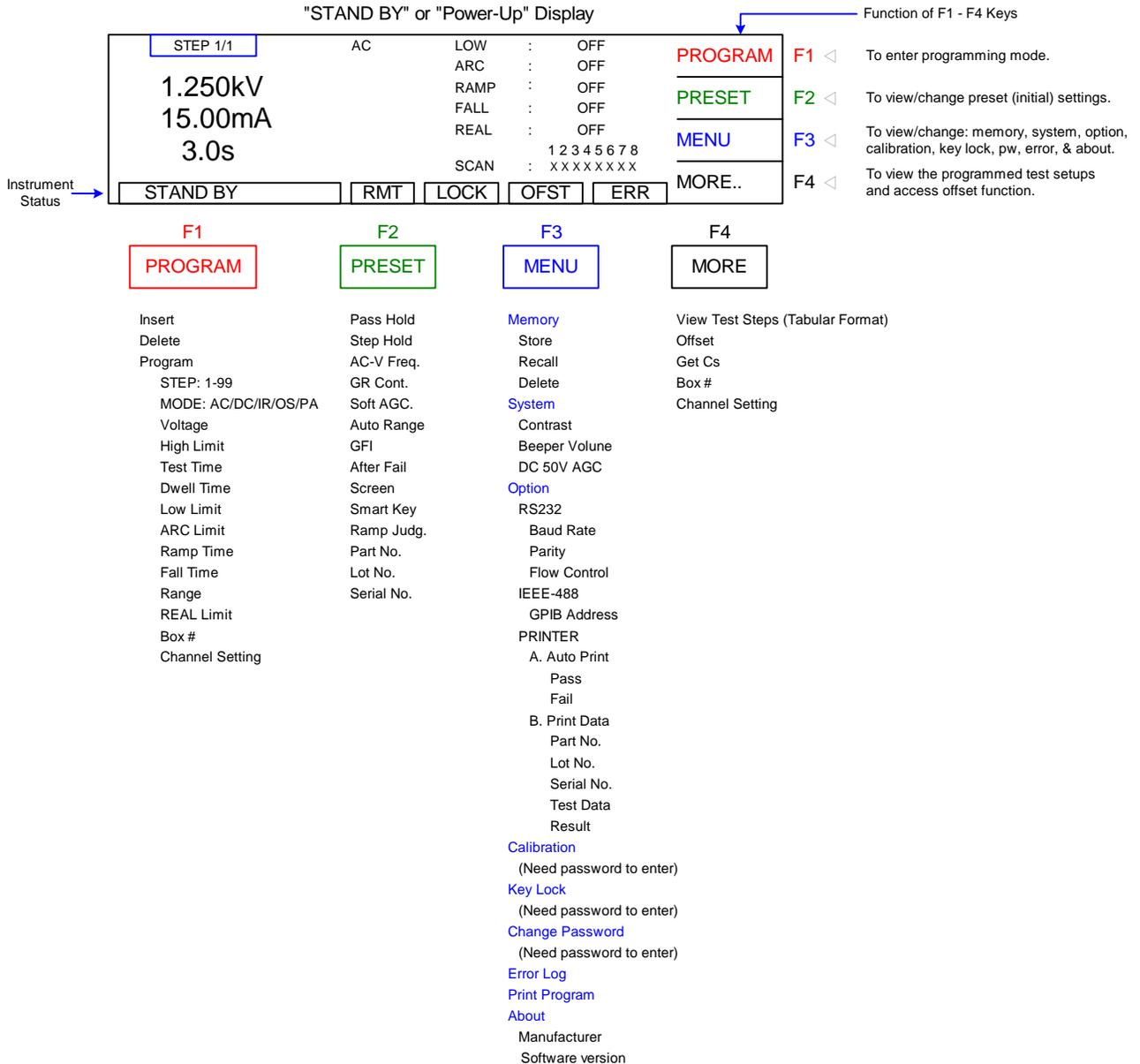

Figure 2-1: STAND BY Function Key Menus

Figure 2-2 illustrates the “STAND BY” or ‘Power-Up’ display. Also illustrated in Figure 2-3 are the PROGRAM display and the five test mode displays (AC, DC, IR, OS or PA).

The Guardian 1000 Series instruments have multiple menus or displays that may seem confusing at first glance. In an attempt to clarify the numerous functions of the software, this instruction manual will illustrate these displays in a (hopefully) logical format. The function keys (F1, F2, F3 & F4) perform different tasks depending upon the menu currently shown on the display. Figure 2-2 illustrates the STAND BY display shown upon instrument ‘power-up’.

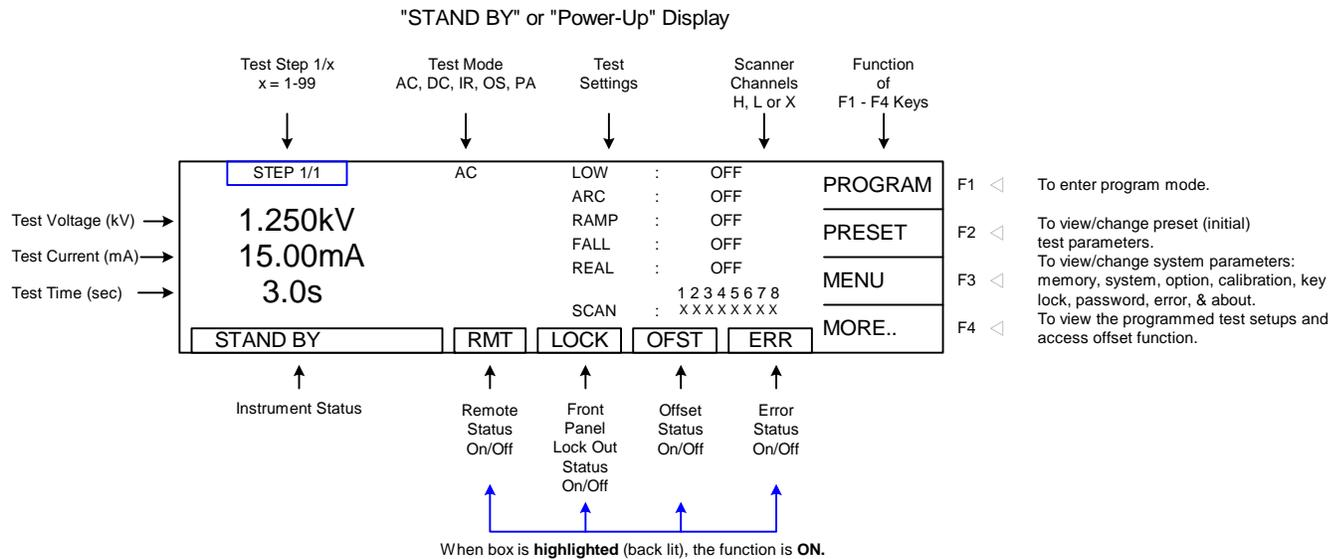

Figure 2-2: STAND BY Display

To access the programming function of the G1000 Series instrument in the STAND BY menu, press the [F1] key (PROGRAM). Once in the PROGRAM display, select the test step then the test mode (AC, DC, IR, OS or PA). From here you can program the individual parameters of each test. Refer to Figure 2-3 for an illustration of the “STAND BY” display, the PROGRAM display and the four test mode displays (AC, DC, IR, OS or PA). Paragraphs 2.4, 2.5, 2.6, 2.7 and 2.8 illustrate how to program the specific parameters of each of the 5 tests.

The Stand By display as shown when the G1000 instrument is powered up. The box in the lower left hand corner denotes the instrument status. For clarity, a green arrow (→) is used to denote which function key (F1 – F4) is pressed to get to the next display screen.

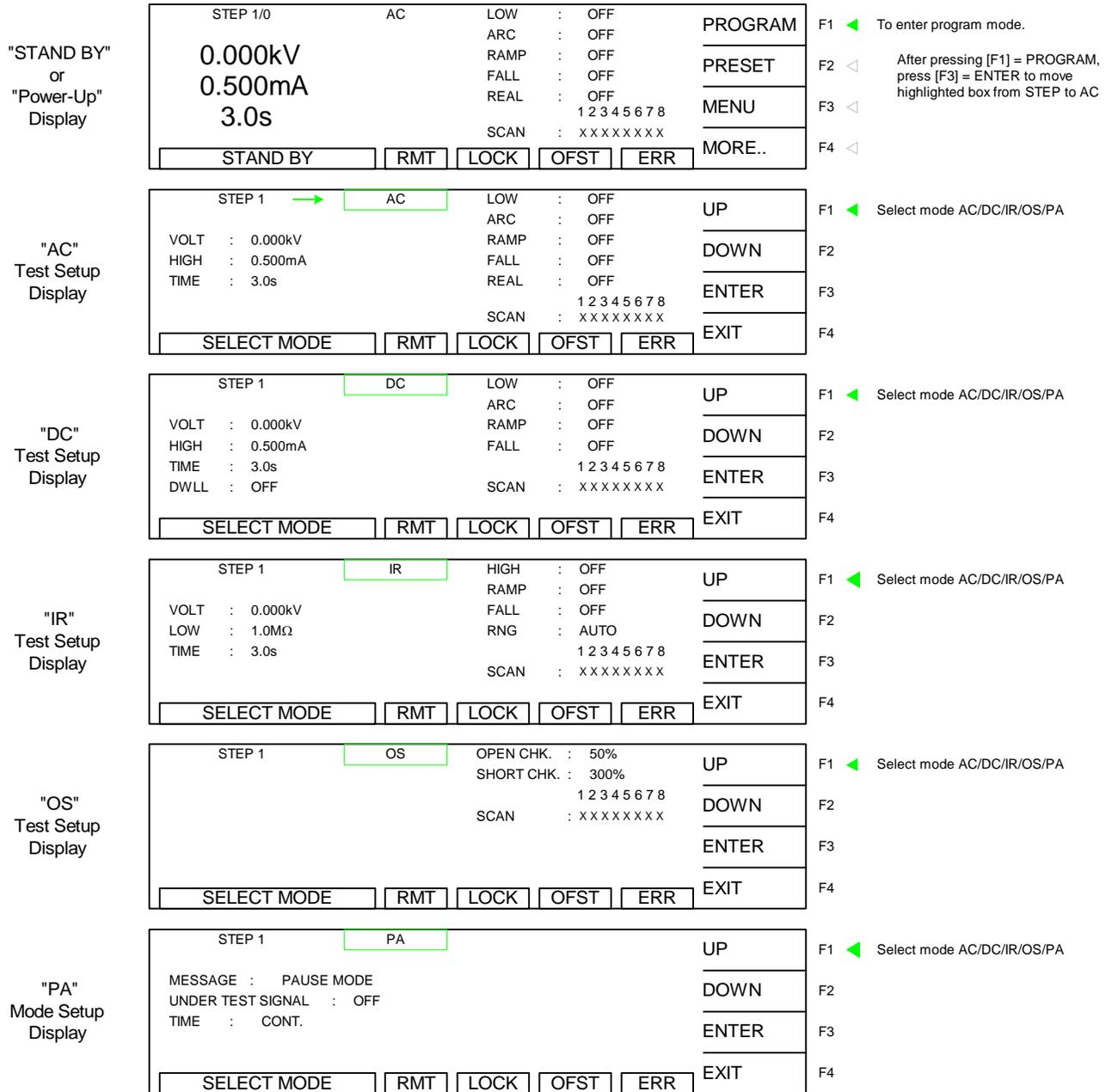

Figure 2-3: STAND BY & Test Mode Displays

2.4 Programming an Open/Short (OS) Circuit Check

The Open/Short Circuit Detection Mode will ensure the Device Under Test is connected properly and that it does not have a short circuit. In Program mode OS can be selected as one of the steps within the test. There are two programmable parameters Open % and Short %. Open % is equivalent to a low limit. Short % would be considered a high limit. Once programming is finalized, an offset should be performed and the Get Cs function must be ran to learn the Capacitance of the device under test. This learned Capacitance value will then be compared to the Open % and Short % for Pass/Fail judgment. This function is typically programmed prior to a hipot test to check the connection to the device under test before applying high voltage.

Open Check: In hipot testing, a low leakage current may generate a PASS. If the connection is faulty between the hipot and the DUT, the test could pass even if the DUT was not tested. Open Check is similar to using a low limit in an AC hipot test to ensure the connection of the DUT. In some cases, such as DC Hipot, a low limit is not feasible. Open Check will ensure that the DUT is connected.

The Open Check sets the judgment test result (Pass/Fail) to open circuit condition and compares the test reading with the standard capacitance value (Cs). If the test reading is within the programmed % then the judgment is Pass. The Open Check can be programmed from 10% - 100% and the default 50%.

Short Check: In some cases, the DUT is shorted prior to testing. If the product is shorted, there is no need to perform hipot.

The Short Check sets the judgment test result (Pass/Fail) to short circuit condition and compares the test reading to the standard capacitance value (Cs). If the test reading is within the programmed % then the judgment is Pass. The Short Check can be set to Off or programmed from 100% - 500%. The default value is 300%.

When using OS mode, program the test, attach the DUT, press [F4] = MORE and then [F2] = GET Cs to obtain the DUT's standard capacitance value. The Cs value is saved with the test program in instrument memory. The Cs value is applicable to that product only.

To illustrate this function: for a particular DUT, the Guardian instrument learned Cs = 0.241nF and the Open Check is set to 50%. If the measured Cs is within 50% of the learned Cs, then the OSC result is a PASS. If the measured Cs is greater than 0.121nF (50% of .241nF), then the OSC result is a PASS. If the measured Cs is less than 0.121nF, then the OSC result is an OPEN.

If the Short Check is set to 300%. If the measured Cs is less than 300% of the learned Cs, then the OSC result is a PASS. If the measured Cs is greater than 300% of the learned Cs, then the OSC result is a FAIL. If the measured Cs is greater than 0.723nF (300% of .241nF), then the OSC result is a SHORT.

NOTE:

To obtain consistent results, the Offset function must be performed when using OS mode. The Offset function is performed prior to the Get Cs function.

Open/Short (OS) Circuit Check

This test is applicable to the Guardian 1010, 1030 and 1030S instruments. With the instrument in 'stand-by' status, press [F1] = PROGRAM. Follow the **green** arrows (□) on the right side of this diagram to program the individual OS parameters.

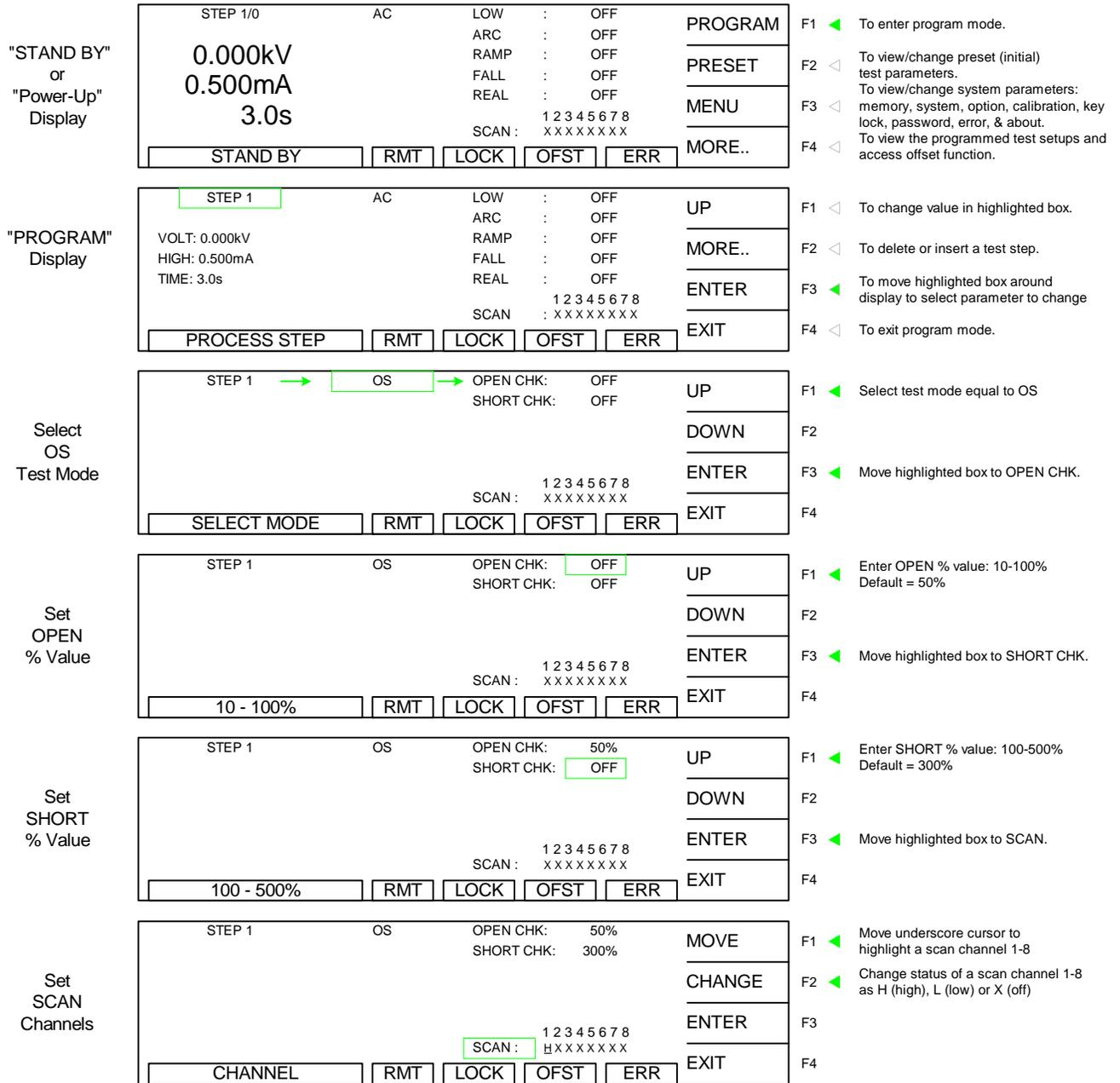

END OS Programming. After selecting the short % value, either press [F3] = ENTER to move the highlighted box to STEP and start programming STEP 2-99 OR press [F4] = EXIT to exit program mode and return to STAND BY status.

2.5 Programming an AC Hipot Test

This test is applicable to the Guardian 1010, 1030 and 1030S instruments. With the instrument in 'stand-by' status, press [F1] = PROGRAM. Follow the **green** arrows (□) on the right side of this diagram to program the individual AC hipot test parameters. The example illustrated herein shows an OS check as Step 1 and how to program an AC test in Step 2.

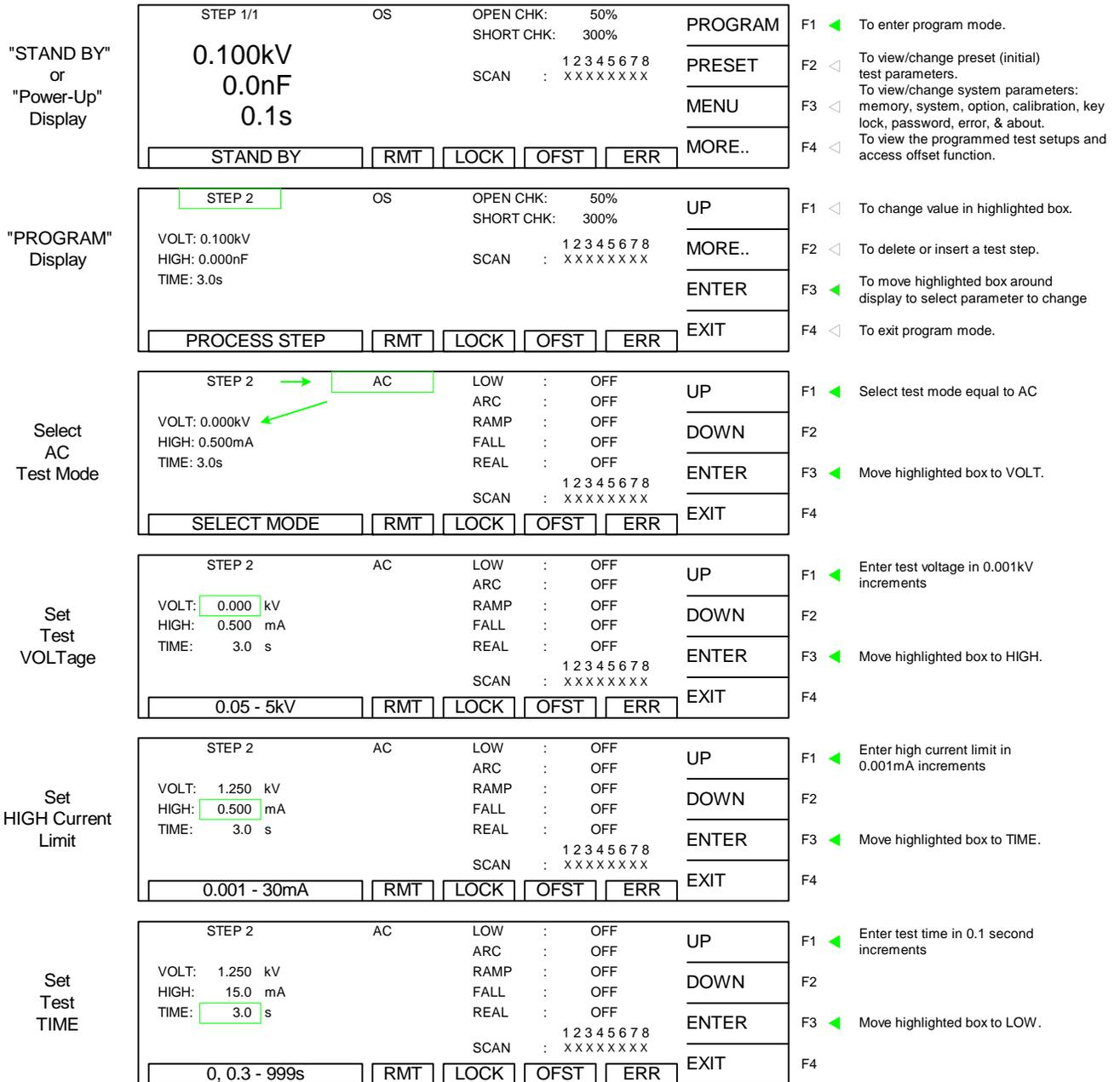

Continue on next page.

Programming an AC Hipot Test (Continued)

Set LOW Current Limit	STEP 2	AC	LOW : OFF	UP	F1	Enter low current limit in 0.001mA increments
	VOLT: 1.250 kV		ARC : OFF	DOWN	F2	
	HIGH: 15.0 mA		RAMP : OFF	ENTER	F3	Move highlighted box to ARC.
	TIME: 3.0 s		FALL : OFF	EXIT	F4	
			REAL : OFF			
			SCAN : 1 2 3 4 5 6 7 8 : X X X X X X X X			
	0 - 30mA	0=OFF	RMT	LOCK	OFST	ERR
Set ARC Limit	STEP 2	AC	LOW : OFF	UP	F1	Enter ARC limit in 0.001mA increments
	VOLT: 1.250 kV		ARC : OFF	DOWN	F2	
	HIGH: 1.000 mA		RAMP : OFF	ENTER	F3	Move highlighted box to RAMP.
	TIME: 3.0 s		FALL : OFF	EXIT	F4	
			REAL : OFF			
			SCAN : 1 2 3 4 5 6 7 8 : X X X X X X X X			
	0 - 15mA	0=OFF	RMT	LOCK	OFST	ERR
Set RAMP Time	STEP 2	AC	LOW : OFF	UP	F1	Enter ramp time in 0.1 second increments
	VOLT: 1.250 kV		ARC : OFF	DOWN	F2	
	HIGH: 15.0 mA		RAMP : OFF	ENTER	F3	Move highlighted box to FALL.
	TIME: 3.0 s		FALL : OFF	EXIT	F4	
			REAL : OFF			
			SCAN : 1 2 3 4 5 6 7 8 : X X X X X X X X			
	0 - 999s	0=OFF	RMT	LOCK	OFST	ERR
Set FALL Time	STEP 2	AC	LOW : OFF	UP	F1	Enter fall time in 0.1 second increments
	VOLT: 1.250 kV		ARC : OFF	DOWN	F2	
	HIGH: 15.0 mA		RAMP : OFF	ENTER	F3	Move highlighted box to REAL.
	TIME: 3.0 s		FALL : OFF	EXIT	F4	
			REAL : OFF			
			SCAN : 1 2 3 4 5 6 7 8 : X X X X X X X X			
	0 - 999s	0=OFF	RMT	LOCK	OFST	ERR
Set REAL Current Limit	STEP 2	AC	LOW : OFF	UP	F1	Enter real current ON or OFF in 0.001mA increments.
	VOLT: 1.250 kV		ARC : OFF	DOWN	F2	
	HIGH: 0.500 mA		RAMP : OFF	ENTER	F3	Move highlighted box to SCAN.
	TIME: 3.0 s		FALL : OFF	EXIT	F4	
			REAL : OFF			
			SCAN : 1 2 3 4 5 6 7 8 : X X X X X X X X			
	0 - 30mA	0=OFF	RMT	LOCK	OFST	ERR
Set SCAN Channels	STEP 2	AC	LOW : OFF	MOVE	F1	Move underscore cursor to highlight a scan channel 1-8.
	VOLT: 1.250 kV		ARC : OFF	CHANGE	F2	Change status of a scan channel 1-8 as H (high), L (low) or X (OFF).
	HIGH: 15.0 mA		RAMP : OFF	ENTER	F3	
	TIME: 10.0 s		FALL : OFF	EXIT	F4	
			REAL : OFF			
			SCAN : 1 2 3 4 5 6 7 8 : H X X X X X X X			
	SELECT BOXS	RMT	LOCK	OFST	ERR	
EXIT or Program More	STEP 2	AC	LOW : OFF	MOVE	F1	Move highlighted box to STEP and immediately program another step.
	VOLT: 1.250 kV		ARC : OFF	CHANGE	F2	OR
	HIGH: 15.0 mA		RAMP : OFF	ENTER	F3	EXIT programming mode and return to STAND BY status.
	TIME: 10.0 s		FALL : OFF	EXIT	F4	
			REAL : OFF			
			SCAN : 1 2 3 4 5 6 7 8 : H X X X X X X X			
	CHANNEL	RMT	LOCK	OFST	ERR	

END AC Hipot Test Programming. After selecting the scan channels, either press [F3] = ENTER to move the highlighted box to STEP and start programming STEP 3-99 OR press [F4] = EXIT to exit program mode and return to STAND BY status.

2.6 Programming a Pause

This test is applicable to the Guardian 1010, 1030 and 1030S instruments. With the instrument in 'stand-by' status, press [F1] = PROGRAM. Follow the **green** arrows (□) on the right side of this diagram to program the individual PA mode parameters. The example illustrated herein shows an OS check as Step 1, an AC Hipot as Step 2 and how to program a PA in Step 3.

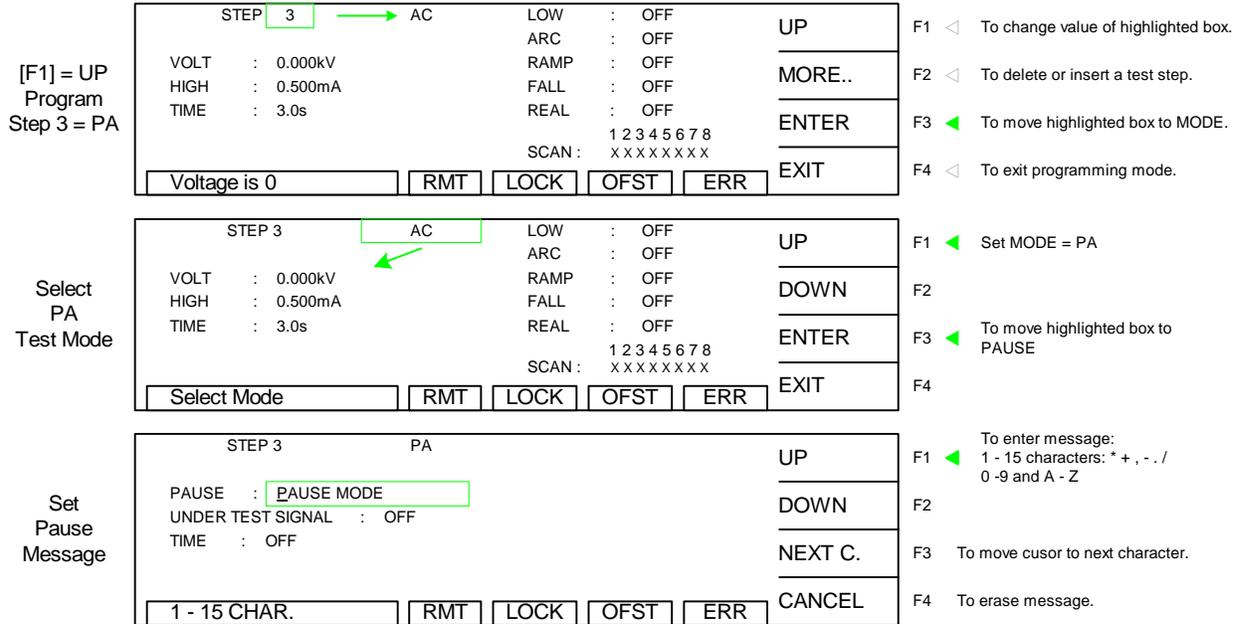

A 1-15 character alpha-numeric message may be set to be displayed on the screen during Pause Mode. Characters allowed: 0-9; A-Z; - and _ . To set this example message:

Press [F3] = ENTER ⇒ MESSAGE: PAUSE MODE

Press [F1] = UP and the display reads MESSAGE: _

Press [F1] = UP to select 1st character (C); press [F3] = NEXT C. to move cursor right.

Press [F1] = UP to select 2nd character (H); press [F3] = NEXT C. to move cursor right.

Press [F1] = UP to select 3rd character (A); press [F3] = NEXT C. to move cursor right.

Press [F1] = UP to select 4th character (N); press [F3] = NEXT C. to move cursor right.

Press [F1] = UP to select 5th character (G); press [F3] = NEXT C. to move cursor right.

Press [F1] = UP to select 6th character (E); press [F3] = NEXT C. to move cursor right.

Continue this process until MESSAGE: CHANGE DUT

Continued on next page.

Programming a Pause (Continued)

Enter Pause Message	STEP 3 PA	UP	F1
	PAUSE : CHANGE-DUT	DOWN	F2
	UNDER TEST SIGNAL : OFF	ENTER	F3 To move highlighted box to UNDER TEST SIGNAL
	TIME : OFF	CANCEL	F4
	1 - 15 CHAR. RMT LOCK OFST ERR		
Set Test Signal	STEP 3 PA	UP	F1 To set test signal: OFF or ON
	PAUSE : CHANGE-DUT	DOWN	F2
	UNDER TEST SIGNAL : OFF	ENTER	F3 To move highlighted box to TIME
	TIME : OFF	EXIT	F4
	OFF / ON RMT LOCK OFST ERR		
Set Pause Time	STEP 3 PA	UP	F1 To set Pause Time: 0-999s
	PAUSE : CHANGE-DUT	DOWN	F2
	UNDER TEST SIGNAL : OFF	ENTER	F3
	TIME : OFF	EXIT	F4 To move highlighted box to STEP
	0, 0.3 -999s RMT LOCK OFST ERR		
EXIT or Program More	STEP 3 PA	UP	F1
	PAUSE : CHANGE-DUT	DOWN	F2
	UNDER TEST SIGNAL : OFF	ENTER	F3 Move highlighted box to STEP and immediately program another step
	TIME : 5.0s	EXIT	F4 To exit programming mode and return to STAND BY status.
	0, 0.3 -999s RMT LOCK OFST ERR		

End Pause programming instructions. After setting the pause time, either press [F3] = ENTER to move the highlighted box to STEP and start programming STEP 4-99 OR press [F4] = EXIT to exit program mode and return to STAND BY status.

2.7 Programming a DC Hipot Test

This test is applicable to the Guardian 1030 and 1030S instruments. With the instrument in 'stand-by' status, press [F1] = PROGRAM. The example illustrated herein shows an OS check as Step 1, an AC test as Step 2, a PA as Step 3 and how to program a DC test in Step 4.

"STAND BY" or "Power-Up" Display	STEP 2/3	AC	LOW : OFF	PROGRAM	F1 ◀	To enter program mode.
	1.250kV		ARC : OFF	PRESET	F2 ◀	To view/change preset (initial) test parameters.
	15.00mA		RAMP : OFF	MENU	F3 ◀	To view/change system parameters: memory, system, option, calibration, key lock, password, error, & about.
	3.0s		FALL : OFF	MORE..	F4 ◀	To view the programmed test setups and access offset function.
			REAL : OFF			
			SCAN : 1 2 3 4 5 6 7 8			
			: X X X X X X X X			
	STAND BY	RMT	LOCK	OFST	ERR	
"PROGRAM" Display	STEP 2	AC	LOW : OFF	UP	F1 ◀	To change value in highlighted box.
	VOLT: 1.250kV		ARC : OFF	MORE..	F2 ◀	To delete or insert a test step.
	HIGH: 15.0mA		RAMP : OFF	ENTER	F3 ◀	To move highlighted box around display to select parameter to change
	TIME: 3.0s		FALL : OFF	EXIT	F4 ◀	To exit program mode.
			REAL : OFF			
			SCAN : 1 2 3 4 5 6 7 8			
			: X X X X X X X X			
	PROCESS STEP	RMT	LOCK	OFST	ERR	
Select STEP #	STEP 4	AC	LOW : OFF	UP	F1 ◀	To change value of highlighted box.
	VOLT: 1.250kV		ARC : OFF	MORE..	F2 ◀	To delete or insert a test step.
	HIGH: 15.0mA		RAMP : OFF	ENTER	F3 ◀	To move highlighted box around display to select parameter to change
	TIME: 3.0s		FALL : OFF	EXIT	F4 ◀	To exit program mode.
			REAL : OFF			
			SCAN : 1 2 3 4 5 6 7 8			
			: X X X X X X X X			
	PROCESS STEP	RMT	LOCK	OFST	ERR	
Select DC Test Mode	STEP 4	DC	LOW : OFF	UP	F1 ◀	Change test mode to DC.
	VOLT: 0.000kV		ARC : OFF	DOWN	F2	
	HIGH: 0.500mA		RAMP : OFF	ENTER	F3 ◀	Move highlighted box to VOLT.
	TIME: 3.0s		FALL : OFF	EXIT	F4	
	DWLL: OFF		REAL : OFF			
			SCAN : 1 2 3 4 5 6 7 8			
			: X X X X X X X X			
	SELECT MODE	RMT	LOCK	OFST	ERR	
Set Test VOLTage	STEP 4	DC	LOW : OFF	UP	F1 ◀	Enter test voltage in 0.001kV increments
	VOLT: 0.000 kV		ARC : OFF	DOWN	F2	
	HIGH: 0.500 mA		RAMP : OFF	ENTER	F3 ◀	Move highlighted box to HIGH.
	TIME: 3.0 s		FALL : OFF	EXIT	F4	
	DWLL: OFF		REAL : OFF			
			SCAN : 1 2 3 4 5 6 7 8			
			: X X X X X X X X			
	0.05 - 6kV	RMT	LOCK	OFST	ERR	
Set HIGH Current Limit	STEP 4	DC	LOW : OFF	UP	F1 ◀	Enter high current limit from 0.1uA- 0.9uA in 0.1uA increments and from 0.001mA-10mA in 0.001mA increments
	VOLT: 2.500 kV		ARC : OFF	DOWN	F2	
	HIGH: 0.500 mA		RAMP : OFF	ENTER	F3 ◀	Move highlighted box to TIME.
	TIME: 3.0 s		FALL : OFF	EXIT	F4	
	DWLL: OFF		REAL : OFF			
			SCAN : 1 2 3 4 5 6 7 8			
			: X X X X X X X X			
	0.0001 - 10mA	RMT	LOCK	OFST	ERR	
Set Test TIME	STEP 4	DC	LOW : OFF	UP	F1 ◀	Enter test time in 0.1 second increments
	VOLT: 2.500 kV		ARC : OFF	DOWN	F2	
	HIGH: 15.0 mA		RAMP : OFF	ENTER	F3 ◀	Move highlighted box to DWLL.
	TIME: 3.0 s		FALL : OFF	EXIT	F4	
	DWLL: OFF		REAL : OFF			
			SCAN : 1 2 3 4 5 6 7 8			
			: X X X X X X X X			
	0, 0.3 - 999s	RMT	LOCK	OFST	ERR	

Continue on next page.

Programming an DC Hipot Test (Continued)

Set DWELL TIME	STEP 4	DC	LOW : OFF	UP	F1	Enter dwell time in 0.1 second increments Move highlighted box to LOW.
	VOLT: 2.500 kV		ARC : OFF	DOWN	F2	
	HIGH: 15.0 mA		RAMP : OFF	ENTER	F3	
	TIME: 3.0 s		FALL : OFF	EXIT	F4	
	DWLL: OFF		SCAN : 1 2 3 4 5 6 7 8 : X X X X X X X X			
	0, 0.3 - 999s	RMT	LOCK	OFST	ERR	EXIT
Set LOW Current Limit	STEP 4	DC	LOW : OFF	UP	F1	Enter low current limit in 0.001mA increments Move highlighted box to ARC.
	VOLT: 1.250 kV		ARC : OFF	DOWN	F2	
	HIGH: 10.0 mA		RAMP : OFF	ENTER	F3	
	TIME: 3.0 s		FALL : OFF	EXIT	F4	
	DWLL: 3.0 s		SCAN : 1 2 3 4 5 6 7 8 : X X X X X X X X			
	0 - 10mA 0=OFF	RMT	LOCK	OFST	ERR	EXIT
Set ARC Limit	STEP 4	DC	LOW : OFF	UP	F1	Enter ARC limit in 0.001mA increments Move highlighted box to RAMP.
	VOLT: 1.250 kV		ARC : OFF	DOWN	F2	
	HIGH: 1.000 mA		RAMP : OFF	ENTER	F3	
	TIME: 3.0 s		FALL : OFF	EXIT	F4	
	DWLL: 3.0 s		SCAN : 1 2 3 4 5 6 7 8 : X X X X X X X X			
	1 - 10mA 0=OFF	RMT	LOCK	OFST	ERR	EXIT
Set RAMP Time	STEP 4	DC	LOW : OFF	UP	F1	Enter ramp time in 0.1 second increments Move highlighted box to FALL.
	VOLT: 1.250 kV		ARC : OFF	DOWN	F2	
	HIGH: 10.0 mA		RAMP : OFF	ENTER	F3	
	TIME: 3.0 s		FALL : OFF	EXIT	F4	
	DWLL: 3.0 s		SCAN : 1 2 3 4 5 6 7 8 : X X X X X X X X			
	0 - 999s 0=OFF	RMT	LOCK	OFST	ERR	EXIT
Set FALL Time	STEP 4	DC	LOW : OFF	UP	F1	Enter fall time in 0.1 second increments Move highlighted box to SCAN.
	VOLT: 1.250 kV		ARC : OFF	DOWN	F2	
	HIGH: 10.0 mA		RAMP : OFF	ENTER	F3	
	TIME: 3.0 s		FALL : OFF	EXIT	F4	
	DWLL: 3.0 s		SCAN : 1 2 3 4 5 6 7 8 : X X X X X X X X			
	0 - 999s 0=OFF	RMT	LOCK	OFST	ERR	EXIT
Set SCAN Channels	STEP 4	DC	LOW : OFF	MOVE	F1	Move underscore cursor to highlight a scan channel 1-8. Change status of a scan channel 1-8 as H (high), L (low) or X (OFF).
	VOLT: 1.250 kV		ARC : OFF	CHANGE	F2	
	HIGH: 10.0 mA		RAMP : OFF	ENTER	F3	
	TIME: 3.0 s		FALL : OFF	EXIT	F4	
	DWLL: 3.0 s		SCAN : 1 2 3 4 5 6 7 8 : H X X X X X X X			
	SELECT BOXS	RMT	LOCK	OFST	ERR	EXIT
EXIT or Program More	STEP 4	DC	LOW : OFF	MOVE	F1	Move highlighted box to STEP and immediately program another step. Exit programming mode and return to STAND BY status.
	VOLT: 1.250 kV		ARC : OFF	CHANGE	F2	
	HIGH: 10.0 mA		RAMP : OFF	ENTER	F3	
	TIME: 3.0 s		FALL : OFF	EXIT	F4	
	DWLL: 3.0 s		SCAN : 1 2 3 4 5 6 7 8 : H X X X X X X X			
	CHANNEL	RMT	LOCK	OFST	ERR	EXIT

END DC Hipot Test Programming. After selecting the scan channels, either press [F3] = ENTER to move the highlighted box to STEP and start programming STEP 5-99 OR press [F4] = EXIT to exit program mode and return to STAND BY status.

2.8 Programming an IR (Insulation Resistance) Test

This test is applicable to the 1030 and 1030S instruments. With the instrument in 'stand-by' status, press [F1] = PROGRAM. This example shows an OS check as Step 1, an AC test as Step 2, a PA as Step 3, a DC test as Step 4 and how to program an IR test in Step 5.

"STAND BY" or "Power-Up" Display	STEP 4/4	DC	LOW : OFF	PROGRAM	F1 ◀ To enter program mode.
	2.500kV		ARC : OFF	PRESET	F2 ◀ To view/change preset (initial) test parameters.
	15.00mA		RAMP : OFF	MENU	F3 ◀ To view/change system parameters: memory, system, option, calibration, key lock, password, error, & about.
	3.0s		FALL : OFF	MORE..	F4 ◀ To view the programmed test setups and access offset function.
	SCAN : 1 2 3 4 5 6 7 8		XXXXXXXXXX		
	STAND BY	RMT	LOCK	OFST	ERR
"PROGRAM" Display & Select Step #	STEP 5	DC	LOW : OFF	UP	F1 ◀ To change value in highlighted box. (Press twice to go to Step 3).
	VOLT: 2.500kV		ARC : OFF	MORE..	F2 ◀ To delete or insert a test step.
	HIGH: 15.0mA		RAMP : OFF	ENTER	F3 ◀ To move highlighted box around display to select parameter to change
	TIME: 3.0s		FALL : OFF	EXIT	F4 ◀ To exit program mode.
	DWLL: 3.0s				
	SCAN : 1 2 3 4 5 6 7 8		XXXXXXXXXX		
	PROCESS STEP	RMT	LOCK	OFST	ERR
Select IR Test Mode	STEP 5	IR	HIGH : OFF	UP	F1 ◀ Select test mode equal to IR
	VOLT: 0.000kV		RAMP : OFF	DOWN	F2
	LOW: 1.0MΩ		FALL : OFF	ENTER	F3 ◀ Move highlighted box to VOLT.
	TIME: 3.0s		RNG : AUTO	EXIT	F4
	SCAN : 1 2 3 4 5 6 7 8		XXXXXXXXXX		
	SELECT MODE	RMT	LOCK	OFST	ERR
Set Test VOLTage	STEP 5	IR	HIGH : OFF	UP	F1 ◀ Enter test voltage in 0.001kV increments
	VOLT: 0.000 kV		RAMP : OFF	DOWN	F2
	LOW: 1.0 MΩ		FALL : OFF	ENTER	F3 ◀ Move highlighted box to LOW.
	TIME: 3.0 s		RNG : AUTO	EXIT	F4
	SCAN : 1 2 3 4 5 6 7 8		XXXXXXXXXX		
	0.05 - 1kV	RMT	LOCK	OFST	ERR
Set LOW Resistance Limit	STEP 5	IR	HIGH : OFF	UP	F1 ◀ Enter low resistance limit in 0.1MΩ increments
	VOLT: 0.500 kV		RAMP : OFF	DOWN	F2
	LOW: 1.0 MΩ		FALL : OFF	ENTER	F3 ◀ Move highlighted box to TIME.
	TIME: 3.0 s		RNG : AUTO	EXIT	F4
	SCAN : 1 2 3 4 5 6 7 8		XXXXXXXXXX		
	0.1 - 50000MΩ	RMT	LOCK	OFST	ERR
Set Test TIME	STEP 5	IR	HIGH : OFF	UP	F1 ◀ Enter test time in 0.1 second increments
	VOLT: 0.500 kV		RAMP : OFF	DOWN	F2
	LOW: 2.5 MΩ		FALL : OFF	ENTER	F3 ◀ Move highlighted box to HIGH.
	TIME: 3.0 s		RNG : AUTO	EXIT	F4
	SCAN : 1 2 3 4 5 6 7 8		XXXXXXXXXX		
	0, 0.3 - 999s	RMT	LOCK	OFST	ERR
Set HIGH Resistance Limit	STEP 5	IR	HIGH : OFF	UP	F1 ◀ Enter high resistance limit in 0.1MΩ increments
	VOLT: 0.500 kV		RAMP : OFF	DOWN	F2
	LOW: 2.5 MΩ		FALL : OFF	ENTER	F3 ◀ Move highlighted box to RAMP.
	TIME: 3.0 s		RNG : AUTO	EXIT	F4
	SCAN : 1 2 3 4 5 6 7 8		XXXXXXXXXX		
	0 - 50GΩ 0=OFF	RMT	LOCK	OFST	ERR

Continue on next page.

Programming an IR Test (Continued)

Set RAMP Time	STEP 5	IR	HIGH : OFF	UP	F1	Enter ramp time in 0.1 second increments
	VOLT: 0.500 kV		RAMP : OFF	DOWN	F2	
	LOW: 2.5 MΩ		FALL : OFF	ENTER	F3	Move highlighted box to FALL
	TIME: 3.0 s		RNG : AUTO	EXIT	F4	
			1 2 3 4 5 6 7 8			
			SCAN : X X X X X X X X			
0 - 999s 0=OFF		RMT	LOCK	OFST	ERR	
Set FALL Time	STEP 5	IR	HIGH : OFF	UP	F1	Enter fall time in 0.1 second increments
	VOLT: 0.500 kV		RAMP : OFF	DOWN	F2	
	LOW: 2.5 MΩ		FALL : OFF	ENTER	F3	Move highlighted box to RNG
	TIME: 3.0 s		RNG : AUTO	EXIT	F4	
			1 2 3 4 5 6 7 8			
			SCAN : X X X X X X X X			
0 - 999s 0=OFF		RMT	LOCK	OFST	ERR	
Set RANGE	STEP 5	IR	HIGH : OFF	UP	F1	Select resistance range
	VOLT: 0.500 kV		RAMP : OFF	DOWN	F2	AUTO; 20-300nA; .3-3uA; 3-30uA; 30-300uA; .3-3mA, 3-10mA
	LOW: 2.5 MΩ		FALL : OFF	ENTER	F3	Move highlighted box to SCAN
	TIME: 3.0 s		RNG : AUTO	EXIT	F4	
			1 2 3 4 5 6 7 8			
			SCAN : X X X X X X X X			
0 - 999s 0=OFF		RMT	LOCK	OFST	ERR	
Set SCAN Channels	STEP 5	IR	HIGH : OFF	MOVE	F1	Move underscore cursor to highlight a scan channel 1-8.
	VOLT: 0.500 kV		RAMP : OFF	CHANGE	F2	Change status of a scan channel 1-8 as H (high), L (low) or X (OFF).
	LOW: 2.5 MΩ		FALL : OFF	ENTER	F3	
	TIME: 3.0 s		RNG : AUTO	EXIT	F4	
			1 2 3 4 5 6 7 8			
			SCAN : X X X X X X X X			
SELECT BOXS		RMT	LOCK	OFST	ERR	
EXIT or Program More	STEP 5	IR	HIGH : OFF	MOVE	F1	Move highlighted box to STEP and immediately program another step.
	VOLT: 0.500 kV		RAMP : OFF	CHANGE	F2	OR
	LOW: 2.5 MΩ		FALL : OFF	ENTER	F3	Exit programming mode and return to STAND BY status.
	TIME: 3.0 s		RNG : AUTO	EXIT	F4	
			1 2 3 4 5 6 7 8			
			SCAN : X X X X X X X X			
CHANNEL		RMT	LOCK	OFST	ERR	

For the sake of this example, we pressed [F4] = EXIT and returned to STAND BY status.

"STAND BY" or "Power-Up" Display	STEP 1/5	OS	OPEN CHK: 50%	PROGRAM	F1	Enter program mode.
	0.100kV		SHORT CHK: 300%	PRESET	F2	View/change preset parameters.
	0.0nF		1 2 3 4 5 6 7 8	MENU	F3	View/change system parameters.
	0.1s		SCAN : X X X X X X X X	MORE..	F4	View the programmed test setups and access Offset & Get Cs functions.
STAND BY		RMT	LOCK	OFST	ERR	

For the sake of this example, we pressed [F4] = MORE to view the 5 Test Setups just programmed (OS/AC/PA/DC/IR)

Test Setups	VOLTAGE MEASURE REAL				OFFSET	F1	Perform OFFSET function.
	1	OS	0.100 kV	0.00 nF	-----		
	2	AC	1.250 kV	15.00 mA	-----		Perform GET Cs (Open/Short) function.
	3	PA	CHANGE DUT		-----		
4	DC	2.500 kV	10.00 mA	-----			
5	IR	0.500 kV	2.50 MΩ	-----	1 2 3 4 5 6 7 8		
					SCAN : X X X X X X X X		
STAND BY		RMT	LOCK	OFST	ERR	MORE..	Return to STAND BY status

END IR Test Programming. For this specific example, press [F4] = MORE to return to STAND BY status.

2.9 Programming a Multi-Step Test

Paragraphs 2.4, 2.5, 2.6, 2.7 and 2.8 illustrate the programming of a 5-step test (OS, AC, PA, DC & IR). To program a multiple step test, power-up the G1000 Series instrument so the ‘Stand By’ display is shown (Figure 2-2). Use the parameters in Table 2-3 and follow the step-by-step instructions to program a 5-step test and save it as “EX” to memory location 01.

Table 2-3: Parameter Settings for 5-Step Example

	OSC	AC Hipot	PA	DC Hipot	IR
1	Test Step #	Test Step #	Test Step #	Test Step #	Test Step #
	1	2	3	4	5
2	Test Mode	Test Mode	Test Mode	Test Mode	Test Mode
	OS	AC	PA	DC	IR
3	Open Check	Voltage	Message	Voltage	Voltage
	50%	1.250kV	Change DUT	2.500kV	0.500kV
4	Short Check	High Limit	UT Signal	High Limit	Low Limit
	300%	15mA	OFF	10mA	2.5MΩ
5		Test Time	Time	Test Time	Test Time
		5.0s	3.0s	5.0s	5.0s
6		Low Limit		Dwell Time	High Limit
		OFF		5.0s	OFF
7		Arc Limit		Low Limit	Ramp Time
		OFF		OFF	5.0s
8		Ramp Time		Arc Limit	Fall Time
		5.0s		OFF	5.0s
9		Fall Time		Ramp Time	Range
		5.0s		5.0s	AUTO
10		Real Limit		Fall Time	Scanner CH
		OFF		5.0s	OFF
11		Scanner CH		Scanner CH	
		OFF		OFF	

From the Standby Menu:

STEP 1/0	AC	LOW : OFF	PROGRAM	F1 ◀
0.000kV		ARC : OFF	PRESET	F2 ◀
0.500mA		RAMP : OFF	MENU	F3 ◀
3.0s		FALL : OFF	MORE..	F4 ◀
		REAL : OFF		
		SCAN : XXXXXXXX		
STAND BY	RMT	LOCK	OFST	ERR
STEP 1	AC	LOW : OFF	UP	F1 ◀
VOLT : 0.000kV		ARC : OFF	DOWN	F2 ◀
HIGH : 0.500mA		FALL : OFF	ENTER	F3 ◀
TIME : 3.0s		RAMP : OFF	EXIT	F4 ◀
		REAL : OFF		
		SCAN : XXXXXXXX		
SELECT MODE	RMT	LOCK	OFST	ERR

Figure 2-4: G1000 Series Standby Menu & Program Menu

Press [F1] = PROGRAM ⇒ Step 1
 Press [F3] = ENTER ⇒ OS
 Press [F3] = ENTER ⇒ OPEN CHK: OFF
 Press [F1] = UP until OPEN CHK: 50%
 Press [F3] = ENTER ⇒ SHORT CHK: OFF
 Press [F1] = UP until HIGH: 300 %
 Press [F3] = ENTER ⇒ SCAN: XXXXXXXX
 Press [F3] = ENTER ⇒ Step 1
 Press [F1] = UP until Step 2
 Press [F3] = ENTER ⇒ AC
 Press [F3] = ENTER ⇒ VOLT: 0.000 kV
 Press [F1] = UP until VOLT: 1.250 kV
 Press [F3] = ENTER ⇒ HIGH: 0.500 mA
 Press [F1] = UP until HIGH: 15.00 mA
 Press [F3] = ENTER ⇒ TIME: 3.0 s
 Press [F1] = UP until TIME: 5.0 s
 Press [F3] = ENTER ⇒ LOW: OFF
 Press [F3] = ENTER ⇒ ARC: OFF
 Press [F3] = ENTER ⇒ RAMP: OFF
 Press [F1] = UP until RAMP: 5.0 s
 Press [F3] = ENTER ⇒ FALL: OFF
 Press [F1] = UP until FALL: 5.0 s
 Press [F3] = ENTER ⇒ REAL: OFF
 Press [F3] = ENTER ⇒ SCAN: XXXXXXXX
 Press [F3] = ENTER ⇒ Step 1
 Press [F1] = UP until Step 3
 Press [F3] = ENTER ⇒ AC
 Press [F1] = UP until PA
 Press [F3] = ENTER ⇒ MESSAGE: PAUSE MODE
 Press [F1] = UP to select 1st character (C); press [F3] = NEXT C. to move cursor right.
 Press [F1] = UP to select 2nd character (H); press [F3] = NEXT C. to move cursor right.
 Press [F1] = UP to select 3rd character (A); press [F3] = NEXT C. to move cursor right.
 Continue this process until MESSAGE: CHANGE DUT
 Press [F3] = ENTER ⇒ UNDER TEST SIGNAL: OFF
 Press [F3] = ENTER ⇒ TIME: OFF
 Press [F1] = UP until TIME: 3.0 s
 Press [F3] = ENTER ⇒ Step 1
 Press [F1] = UP until Step 4
 Press [F3] = ENTER ⇒ AC
 Press [F1] = UP until DC

Press [F3] = ENTER ⇒ VOLT: 0.000 kV
 Press [F1] = UP until VOLT: 2.500 kV
 Press [F3] = ENTER ⇒ HIGH: 0.500 mA
 Press [F1] = UP until HIGH: 10.00 mA
 Press [F3] = ENTER ⇒ TIME: 3.0 s
 Press [F1] = UP until TIME: 5.0 s
 Press [F3] = ENTER ⇒ DWLL: OFF
 Press [F1] = UP until DWLL: 5.0 s
 Press [F3] = ENTER ⇒ LOW: OFF
 Press [F3] = ENTER ⇒ ARC: OFF
 Press [F3] = ENTER ⇒ RAMP: OFF
 Press [F1] = UP until RAMP: 5.0 s
 Press [F3] = ENTER ⇒ FALL: OFF
 Press [F1] = UP until FALL: 5.0 s
 Press [F3] = ENTER ⇒ SCAN: XXXXXXXX
 Press [F3] = ENTER ⇒ Step 1
 Press [F1] = UP until Step 5
 Press [F3] = ENTER ⇒ AC
 Press [F1] = UP until IR
 Press [F3] = ENTER ⇒ VOLT: 0.000 kV
 Press [F1] = UP until VOLT: 0.500 kV
 Press [F3] = ENTER ⇒ LOW: 1.0 MΩ
 Press [F1] = UP until LOW: 2.5 MΩ
 Press [F3] = ENTER ⇒ TIME: 3.0 s
 Press [F1] = UP until TIME: 5.0 s
 Press [F3] = ENTER ⇒ HIGH: OFF
 Press [F3] = ENTER ⇒ RAMP: OFF
 Press [F1] = UP until RAMP: 5.0 s
 Press [F3] = ENTER ⇒ FALL: OFF
 Press [F1] = UP until FALL: 5.0 s
 Press [F3] = ENTER ⇒ RNG: AUTO
 Press [F3] = ENTER ⇒ SCAN: XXXXXXXX
 Press [F3] = ENTER ⇒ Step 1

Press [F4] = EXIT to return to Standby Menu. Follow the next instructions to save the 5-Step Test to Memory Location 1 and give it the label “EX”.

Press [F3] = MENU ⇒ 1. MEMORY
 Press [F3] = SELECT ⇒ 1. (0)
 Press [F1] = STORE ⇒ 1. (0)
 Press [F3] = SELECT ⇒ 1. (0)
 Press [F1] = UP until 1. (0)E
 Press [F3] = ENTER 1. (0)E

Press [F1] = UP until 1. (0)EX

Press [F3] = ENTER 1. (0)EX

Press [F3] = ENTER 1. (0)EX STORE?

Press [F1] = YES 1. (5)EX

Press [F4] = EXIT

Press [F4] = EXIT

Return to Standby Menu with 'M01' in upper left hand corner.

In Stand By status, to view the test steps just programmed press [F4] = MORE. Figure 2-5 illustrates the Stand By display and resultant test setup display if the programming example in paragraphs 2.4-2.8 were followed.

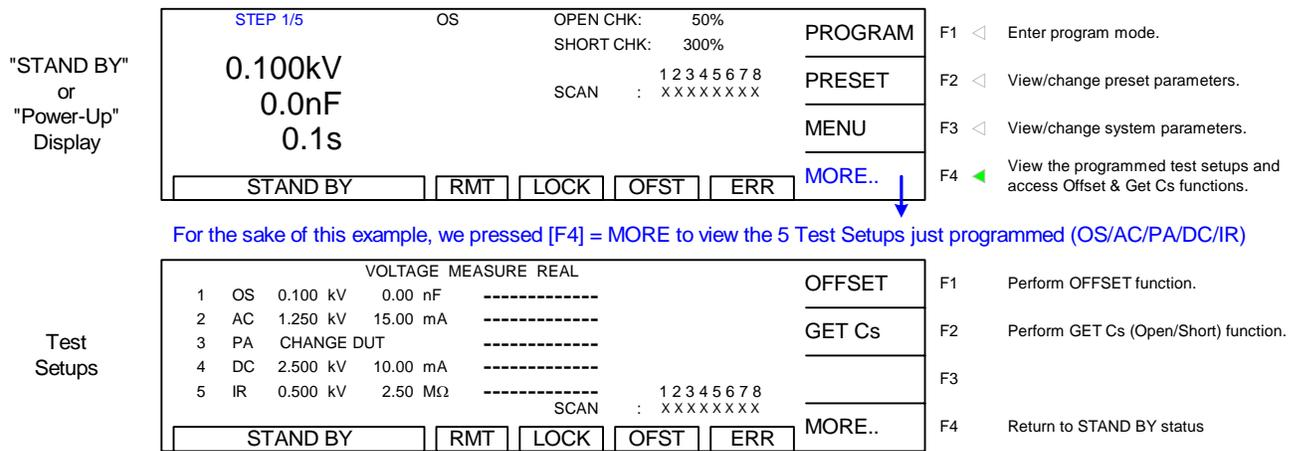

Figure 2-5: View Programmed Test Setups

To view the test results, press [F4] = MORE to go to the tabular display. Use the UP/DOWN key to scroll to the next page.

NOTE:
Exiting the tabular display will clear your test results.

NOTE:
Instrument **PRESET** values can be programmed and stored for your specific test setup. Therefore, **before storing** your tests, program the preset values.

2.9 PRESET Test Parameters

A number of initial parameters or default conditions may be programmed and stored as the 'power-up' conditions. On the Guardian 1000 Series instruments, this function is labeled PRESET and is accessible on the STAND BY display. Table 2-4 lists the Guardian 1000 Series PRESET test parameters including parameter range and initial (default) value.

Table 2-4: PRESET Test Parameters

Parameter	Range	Initial (Default) Value	Description
PASS HOLD	0.2 – 99.9 sec	0.5	Set hold time for a PASS result
STEP HOLD	0 – 99.9 sec KEY	0.2	Set interval time between test steps KEY=Tester will stop after each step and display PASS/FAIL results.
AC-V FREQ.	50 or 60Hz	60	Set frequency for AC Hipot test
GR CONT.	OFF KEY TIME: 0.2 – 99.9s	OFF	Set ground continuity OFF KEY=Tester will display P/F result after each step. TIME: Set test time for GC check
SOFT. AGC	ON or OFF	ON	Set software automatic gain control function ON or OFF
AUTO RANGE	ON or OFF	OFF	Set auto range function ON or OFF
GFI	ON or OFF	ON	Set ground fault interrupt to trip at 0.5mA
AFTER FAIL	CONT., RESTART, STOP	STOP	Continue, Restart or Stop a Test if a Step Fails
SCREEN	ON or OFF	ON	Turns display off to increase test speed
RAMP JUDG.	ON or OFF	ON	Check the high limit during ramp
SMART KEY	ON or OFF	OFF	Scroll through last 10 parameters tested
PART NO.	0-13 characters	Blank	Assign a Part Number
LOT NO.	0-13 characters	Blank	Assign a Lot Number
SERIAL NO.	0, 5-13 characters	Blank	Assign a Serial Number

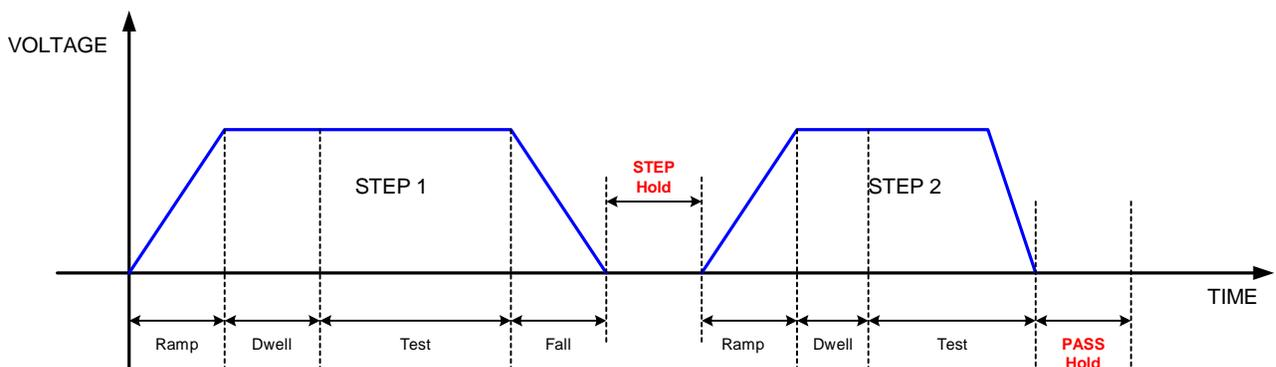

Figure 2-6: Hold Times

2.9.1 PASS HOLD

The Pass Hold setting allows the option of programming a hold time for the PASS relay (at Remote Interface) after a single test or multiple step tests. The range for Pass Hold is 0.2 – 99.9 sec and the instrument default setting is 0.5sec. Refer to Figure 2-6.

To access Pass Hold:

Press [F2] = PRESET

The backlit box is next to 1. PASS HOLD:

Press [F1] = UP or [F2] = DOWN to increase or decrease the Pass Hold time

Press [F3] = ENTER to move backlit box to next parameter

or

Press [F4] = EXIT to exit Preset Menu and return to Standby Menu.

2.9.2 STEP HOLD

The Step Hold setting allows the option of programming a hold time between steps. The range for Step Hold is 0 – 99.9seconds/KEY. The instrument default setting is 0.2sec. When KEY is selected, the unit will stop after each step, display PASS/FAIL result for that step and then the user must press [START] to proceed to the next step.

To access STEP HOLD:

Press [F2] = PRESET

Press [ENTER] until the backlit box is next to 2. STEP HOLD:

Press [F1] = UP or [F2] = DOWN to increase or decrease the Step Hold time

Press [F3] = ENTER to move backlit box to next parameter

or

Press [F4] = EXIT to exit Preset Menu and return to Standby Menu.

2.9.3 AC-V FREQ.

The AC V Frequency setting allows the option of selecting the frequency for the AC hipot test. The range of AC-V Freq. is 50 or 60Hz and the instrument default setting is 60Hz.

To access AC-V FREQ:

Press [F2] = PRESET

Press [ENTER] until the backlit box is next to 3. AC-V FREQ:

Press [F1] = UP or [F2] = DOWN to change the AC-V Frequency to 50/60Hz

Press [F3] = ENTER to move backlit box to next parameter

or

Press [F4] = EXIT to exit Preset Menu and return to Standby Menu.

2.9.4 GR CONT.

The GR CONT. setting has three options for the Ground Continuity (GR) function: OFF, KEY or TIME (0.2-99.9s). The instrument default setting is OFF. When KEY is selected, the G1000 Series instrument will check that the ground resistance is $<1\Omega$ at the start of a test. When TME is selected, a value between 0.2 and 99.9 seconds can be programmed for the amount of time the ground continuity check will be held. If OFF is selected the ground continuity will not be checked.

To access GR CONT:

Press [F2] = PRESET

Press [ENTER] until the backlit box is next to 4. GR CONT:

Press [F1] = UP or [F2] = DOWN to change the Ground Continuity Check to OFF/KEY/TIME

Press [F3] = ENTER to move backlit box to next parameter

or

Press [F4] = EXIT to exit Preset Menu and return to Standby Menu.

2.9.5 SOFT AGC

The Software Automatic Gain Control (SOFT AGC) setting allows the option of correcting the output voltage (ON). This is satisfactory when measuring resistors but under special circumstances when measuring large capacitive devices it is best to select Software AGC OFF. The default value is ON.

To access SOFT AGC:

Press [F2] = PRESET

Press [ENTER] until the backlit box is next to 5. SOFT AGC:

Press [F1] = UP or [F2] = DOWN to change Software AGC to ON/OFF

Press [F3] = ENTER to move backlit box to next parameter

or

Press [F4] = EXIT to exit Preset Menu and return to Standby Menu.

2.9.6 AUTO RANGE

The Auto Range setting allows the option of using the full scale current range (ON) or using the user programmed maximum current limit (OFF). The low current range (3mA full scale) results in increased measurement resolution. The default value of Auto Range is OFF.

To access AUTO RANGE:

Press [F2] = PRESET

Press [ENTER] until the backlit box is next to 6. AUTO RANGE:

Press [F1] = UP or [F2] = DOWN to change Auto Range to ON/OFF

Press [F3] = ENTER to move backlit box to next parameter

or

Press [F4] = EXIT to exit Preset Menu and return to Standby Menu.

2.9.7 GFI

The Ground Fault Interrupt (GFI) function can be programmed ON or OFF. The instrument default setting is ON. When GFI is activated, the ground fault interrupt circuit is set to trip at 0.5mA.

To access GFI:

Press [F2] = PRESET

Press [ENTER] until the backlit box is next to 7. GFI: ON

Press [F1] = UP or [F2] = DOWN to change the Ground Fault Interrupt to ON/OFF

Press [F3] = ENTER to move backlit box to next parameter

or

Press [F4] = EXIT to exit Preset Menu and return to Standby Menu.

2.9.8 AFTER FAIL

The AFTER FAIL function can be programmed to CONTINUE, RESTART or STOP. The default setting is STOP. This selection determines what action the instrument will take when a fail is encountered during a multi-step test. When CONTINUE is selected and a test fails, then the instrument proceeds to the next step in the program. When RESTART is selected and a test fails, [START] can be pressed again to immediately retest. When STOP is selected and a test fails then the unit will stop and the [STOP] button must be pressed. Exception: if Ground Fault Interrupt (GFI) is ON and a GFI failure occurs, the instrument will shut down.

To access FAIL CONT:

Press [F2] = PRESET

Press [ENTER] until the backlit box is next to 8. FAIL CONT: OFF

Press [F1] = UP or [F2] = DOWN to change Continue Step on Fail to ON/OFF

Press [F3] = ENTER to move backlit box to next parameter

or

Press [F4] = EXIT to exit Preset Menu and return to Standby Menu.

2.9.9 SCREEN

The SCREEN function disables the display while testing. It can be set to ON or OFF. When set to OFF, the display is blank and the time is decreased by approximately 100milliseconds. The pass/fail LED indicators and DANGER LED are operational and will show test results in addition to the Remote I/O interface.

To access SCREEN:

Press [F2] = PRESET

Press [ENTER] until the backlit box is next to 9. SCREEN: OFF

Press [F1] = UP or [F2] = DOWN to change Screen to ON/OFF

Press [F3] = ENTER to move backlit box to next parameter

or

Press [F4] = EXIT to exit Preset Menu and return to Standby Menu.

2.9.10 SMART KEY

Applicable to software version 2.22 or higher, this programming function retains the last ten (10) test parameters previously run. When in program mode and SMART key is ON, the UP/DOWN function key will permit the user to scroll through the last ten parameters tested.

To turn SMART Key ON:

Press [F2] = PRESET

Press [ENTER] until the backlit box is next to 10. SMART KEY: **OFF**

Press [F1] = UP to select SMART KEY: **ON**

Press [F4] = EXIT to exit Preset Menu and return to Standby Menu.

Press [F1] = Program

In program menu, press and hold [ENTER = F3] until "S-KEY" is displayed in lower left hand corner. Refer to Figure 2.5.

To turn SMART Key OFF:

Press and hold [ENTER = F3] for approximately 1 second.

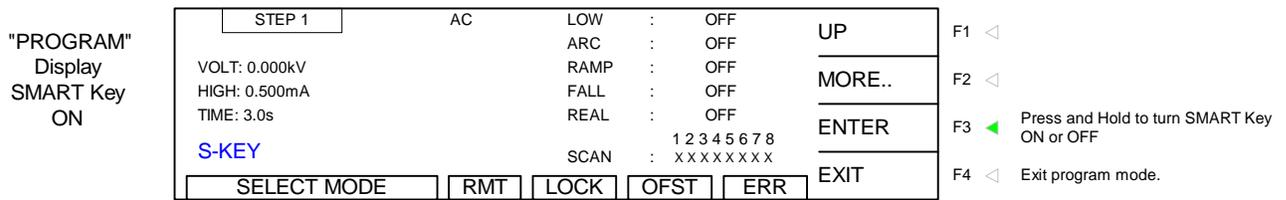

Figure 2.7: Smart Key Display

NOTE:

Using SMART Key to program the G1030S instrument:

The SMART Key will save the user some time in the instance of programming the same test for several steps. For example: only needing to change the scanner configuration (switching the high or low connection to Channels 1-8).

Program Test in Step 1

Run Test.

Program Remaining Steps

1. Turn ON Smart Key
2. Press [UP] to go to Step 2
3. Enter each parameter as normal but now selections are limited to the last 10 tests run.
4. Program all steps the same (cannot set scanners with SMART Key ON).
5. Turn SMART Key OFF
6. Scroll through each Step to set Scanners {High, Low or Off (X)}.

2.9.11 RAMP JUDG

The Judgment Wait setting allows the program to look at the high limits during ramp. The range for RAMP JUDG is ON or OFF and the instrument default setting is OFF.

To access RAMP JUDG:

Press [F2] = PRESET

Press [ENTER] until the backlit box is next to 11. RAMP JUDG:

Press [F1] = UP or [F2] = DOWN to select ON or OFF

Press [F3] = ENTER to move backlit box to next parameter

or

Press [F4] = EXIT to exit Preset Menu and return to Standby Menu.

2.9.12 PART NO

The PART NUMBER function allows the operator to assign a part number to the device under test. The part number can be made up of 0-13 alpha or numeric characters.

To access PART NO:

Press [F2] = PRESET

Press [ENTER] until the backlit box is next to 12. PART NO:

Press [F1] = UP to select 1st character: 0-9, and A-Z

Press [F3] = ENTER to move underscored cursor to next character

Press [F1] = UP to select 2nd character: 0-9, and A-Z

Press [F3] = ENTER to move underscored cursor to next character

Press [F1] = UP to select 3rd character: 0-9, and A-Z

Press [F3] = ENTER to move underscored cursor to next character

Continue up to 13 characters

Press [F3] = ENTER twice when part number label is complete

Press [F3] = ENTER to move backlit box to next parameter

or

Press [F4] = EXIT to exit Preset Menu and return to Standby Menu.

2.9.13 LOT NO

The LOT NUMBER function allows the operator to assign a lot number to the device under test. The lot number can be made up of 0-13 alpha or numeric characters.

To access LOT NO:

Press [F2] = PRESET

Press [ENTER] until the backlit box is next to 13. LOT NO:

Press [F1] = UP to select 1st character: 0-9, and A-Z

Press [F3] = ENTER to move underscored cursor to next character

Press [F1] = UP to select 2nd character: 0-9, and A-Z

Press [F3] = ENTER to move underscored cursor to next character

Press [F1] = UP to select 3rd character: 0-9, and A-Z

Press [F3] = ENTER to move underscored cursor to next character

Continue up to 13 characters

Press [F3] = ENTER twice when lot number label is complete

Press [F3] = ENTER to move backlit box to next parameter

or

Press [F4] = EXIT to exit Preset Menu and return to Standby Menu.

2.9.14 SERIAL NO

The SERIAL NUMBER function allows the operator to assign a serial number to the device under test. The serial number can be made up of 0 or 5-13 alpha or numeric characters.

To access SERIAL NO:

Press [F2] = PRESET

Press [ENTER] until the backlit box is next to 14. SERIAL NO:

Press [F1] = UP to select 1st character: 0-9, and A-Z

Press [F3] = ENTER to move underscored cursor to next character

Press [F1] = UP to select 2nd character: 0-9, and A-Z

Press [F3] = ENTER to move underscored cursor to next character

Press [F1] = UP to select 3rd character: 0-9, and A-Z

Press [F3] = ENTER to move underscored cursor to next character

Continue up to 13 characters

Press [F3] = ENTER twice when serial number label is complete

Press [F3] = ENTER to move backlit box to next parameter

or

Press [F4] = EXIT to exit Preset Menu and return to Standby Menu.

Press [F1] = UP (and/or [F2] = DOWN) to enter an alpha/numerical tag/name for this test step. Press [F3] = ENTER after each digit to accept that digit and move on to the next. The tag can be up to 17 characters. When finished entering the numerical tag, press [F3] = ENTER two times. The display will prompt: STORE? Press [F1] = YES to accept storage or [F2] = NO to reject storage. Press [F4] = EXIT two times to return to "STAND BY" status.

"STORE"	1	(0)		UP	F1	Select highlighted memory location and store previously programmed test setup
	2	(0)		DOWN	F2	
	3	(0)		SELECT	F3	
	4	(0)		RETURN	F4	
SELECT MEMORY RMT LOCK OFST ERR						
"I.D. LOCATION"	1	(0)	222	UP	F1	Place a numerical identification (1-22 digits) on the selected memory location
	2	(0)		DOWN	F2	
	3	(0)		ENTER	F3	
	4	(0)		EXIT	F4	
SELECT CHAR. RMT LOCK OFST ERR						
"EXIT"	1	(0)	222	YES	F1	Store test setup. Returns to "MEMORY" Display. Press [F4] = EXIT to return to "MENU"
	2	(0)		NO	F2	
	3	(0)			F3	
	4	(0)			F4	
SELECT CHAR. RMT LOCK OFST ERR						

The MEMORY RECALL and DELETE functions work the same way as STORE. Refer to ¶2.15.1. When the instrument returns to STAND BY status there will be a tag "Mxx" in the upper left hand corner of the display to indicate which memory location is in use (displayed) as shown in Figure 2-8.

"STAND BY" Display with Memory ID	M01	STEP 1/5	OS	OPEN CHK: 50%	PROGRAM	F1
				SHORT CHK: 300%	PRESET	F2
				SCAN : X X X X X X X X	MENU	F3
					MORE..	F4
STAND BY RMT LOCK OFST ERR						
0.100kV 0.0nF 0.1s						

To view/change system parameters: memory, system, option, calibration, key lock, password, error, & about.

Figure 2-8: Memory Identification on STAND BY display

2.11 Instrument Offset

The Guardian 1000 Series instrument provides automatic offset for lead and/or fixture effects. During the offset process a correction is made (subtracted out) as the result of lead leakage current and stored in instrument memory to be applied to ongoing measurements. For maximum measurement accuracy it is recommended that the OFFSET function be performed on the G1000 Series instrument after power up, any time the test parameters are changed and any time the test leads or fixture is changed. **Note:** Offset is not available if test setups have not been programmed.

Prior to performing the OFFSET function:

Allow the instrument to warm up for 15 minutes.

Connect the Test cables (or fixture) to the OUTPUT and RTN/LOW connectors.

Program the test steps.

With the instrument in STAND BY status:

Press [F4] = MORE

Press [F1] = OFFSET

Follow instructions on display: i.e.: connect OPEN across OUTPUT terminal.

Press green [START] button.

Wait while instrument gets OFFSET value.

The **OFST** block at the bottom of the display is now highlighted (back lit).

Press [F4] = MORE to return to STAND BY status.

OR

To undo the OFFSET function:

Press [F1] = OFFSET

Follow prompt on display: "Turn off the offset function?"

Press [F3] = ENTER to turn **off** OFFSET function.

The **OFST** block at the bottom of the display is **not** highlighted now.

The following formulas apply to the offset function:

For Total Offset Current $\leq 100\mu\text{A}$:

$$\text{Display Current} = \sqrt{(\text{Measured total current})^2 - (\text{Offset total current})^2}$$

For Real Current & Total Current $> 100\mu\text{A}$:

$$\text{Display Current} = (\text{Measured real current}) - (\text{Offset real current})$$

NOTE:

To obtain consistent results, the Offset function must be performed when using OS mode. The Offset function is performed prior to the Get Cs function.

OFFSET Function

There is no offset in IR test mode. Using the pre-programmed example from paragraphs 2.4-2.8 of the OS, AC, PA, DC and IR 5-step test the offset function is illustrated herein. There is no offset in IR or PA modes.

"STAND BY" Display with Memory ID	<table border="1"> <tr> <td>M01 STEP 1/5</td> <td>OS</td> <td>OPEN CHK: 50%</td> <td>PROGRAM</td> <td>F1</td> </tr> <tr> <td></td> <td></td> <td>SHORT CHK: 300%</td> <td>PRESET</td> <td>F2</td> </tr> <tr> <td></td> <td></td> <td>SCAN : 1 2 3 4 5 6 7 8</td> <td>MENU</td> <td>F3</td> </tr> <tr> <td></td> <td></td> <td>SCAN : x x x x x x x x</td> <td>MORE..</td> <td>F4</td> </tr> <tr> <td></td> <td>0.100kV</td> <td></td> <td></td> <td></td> </tr> <tr> <td></td> <td>0.0nF</td> <td></td> <td></td> <td></td> </tr> <tr> <td></td> <td>0.1s</td> <td></td> <td></td> <td></td> </tr> <tr> <td></td> <td>STAND BY</td> <td>RMT</td> <td>LOCK</td> <td>OFST</td> <td>ERR</td> </tr> </table>	M01 STEP 1/5	OS	OPEN CHK: 50%	PROGRAM	F1			SHORT CHK: 300%	PRESET	F2			SCAN : 1 2 3 4 5 6 7 8	MENU	F3			SCAN : x x x x x x x x	MORE..	F4		0.100kV					0.0nF					0.1s					STAND BY	RMT	LOCK	OFST	ERR	<p>F4 ◀ Access OFFSET function.</p>																			
	M01 STEP 1/5	OS	OPEN CHK: 50%	PROGRAM	F1																																																									
			SHORT CHK: 300%	PRESET	F2																																																									
			SCAN : 1 2 3 4 5 6 7 8	MENU	F3																																																									
		SCAN : x x x x x x x x	MORE..	F4																																																										
	0.100kV																																																													
	0.0nF																																																													
	0.1s																																																													
	STAND BY	RMT	LOCK	OFST	ERR																																																									
Test Setups	<table border="1"> <tr> <td colspan="4">VOLTAGE MEASURE REAL</td> <td>OFFSET</td> <td>F1</td> </tr> <tr> <td>1</td> <td>OS</td> <td>0.100 kV</td> <td>0.000 nF</td> <td>-----</td> <td></td> </tr> <tr> <td>2</td> <td>AC</td> <td>1.250 kV</td> <td>15.00 mA</td> <td>-----</td> <td></td> </tr> <tr> <td>3</td> <td>PA</td> <td>CHANGE DUT</td> <td></td> <td>-----</td> <td></td> </tr> <tr> <td>4</td> <td>DC</td> <td>2.500 kV</td> <td>0.500 mA</td> <td>-----</td> <td></td> </tr> <tr> <td>5</td> <td>IR</td> <td>0.500 kV</td> <td>2.50 MΩ</td> <td>-----</td> <td></td> </tr> <tr> <td></td> <td></td> <td></td> <td></td> <td>SCAN : 1 2 3 4 5 6 7 8</td> <td>F3</td> </tr> <tr> <td></td> <td></td> <td></td> <td></td> <td>SCAN : x x x x x x x x</td> <td>F4</td> </tr> <tr> <td></td> <td>STAND BY</td> <td>RMT</td> <td>LOCK</td> <td>OFST</td> <td>ERR</td> </tr> <tr> <td></td> <td></td> <td></td> <td></td> <td>MORE..</td> <td></td> </tr> </table>	VOLTAGE MEASURE REAL				OFFSET	F1	1	OS	0.100 kV	0.000 nF	-----		2	AC	1.250 kV	15.00 mA	-----		3	PA	CHANGE DUT		-----		4	DC	2.500 kV	0.500 mA	-----		5	IR	0.500 kV	2.50 MΩ	-----						SCAN : 1 2 3 4 5 6 7 8	F3					SCAN : x x x x x x x x	F4		STAND BY	RMT	LOCK	OFST	ERR					MORE..		<p>F1 ◀ Perform OFFSET function. F2 Perform OPEN/SHORT function. F3 F4 Return to STAND BY status</p>
	VOLTAGE MEASURE REAL				OFFSET	F1																																																								
	1	OS	0.100 kV	0.000 nF	-----																																																									
	2	AC	1.250 kV	15.00 mA	-----																																																									
3	PA	CHANGE DUT		-----																																																										
4	DC	2.500 kV	0.500 mA	-----																																																										
5	IR	0.500 kV	2.50 MΩ	-----																																																										
				SCAN : 1 2 3 4 5 6 7 8	F3																																																									
				SCAN : x x x x x x x x	F4																																																									
	STAND BY	RMT	LOCK	OFST	ERR																																																									
				MORE..																																																										
GET OFFSET	<table border="1"> <tr> <td colspan="4">1. Please open the HV output terminal.</td> <td></td> <td>F1</td> </tr> <tr> <td colspan="4">2. No offset in IR mode.</td> <td></td> <td>F2</td> </tr> <tr> <td colspan="4">PRESS START KEY TO GET OFFSET..</td> <td></td> <td>F3</td> </tr> <tr> <td></td> <td></td> <td></td> <td></td> <td>EXIT</td> <td>F4</td> </tr> <tr> <td></td> <td></td> <td>RMT</td> <td>LOCK</td> <td>OFST</td> <td>ERR</td> </tr> </table>	1. Please open the HV output terminal.					F1	2. No offset in IR mode.					F2	PRESS START KEY TO GET OFFSET..					F3					EXIT	F4			RMT	LOCK	OFST	ERR	<p>F1 START F2  ◀ To GET OFFSET values F3 F4 Return to STAND BY status</p>																														
	1. Please open the HV output terminal.					F1																																																								
	2. No offset in IR mode.					F2																																																								
	PRESS START KEY TO GET OFFSET..					F3																																																								
				EXIT	F4																																																									
		RMT	LOCK	OFST	ERR																																																									
OFFSET ON	<table border="1"> <tr> <td colspan="4">VOLTAGE MEASURE REAL</td> <td>OFFSET</td> <td>F1</td> </tr> <tr> <td>1</td> <td>OS</td> <td>0.055 kV</td> <td>0.233 nF</td> <td>----- P</td> <td></td> </tr> <tr> <td>2</td> <td>AC</td> <td>1.249 kV</td> <td>0.08 mA</td> <td>----- P</td> <td></td> </tr> <tr> <td>3</td> <td>PA</td> <td>CHANGE DUT</td> <td></td> <td>-----</td> <td></td> </tr> <tr> <td>4</td> <td>DC</td> <td>2.501 kV</td> <td>0.000 mA</td> <td>----- P</td> <td></td> </tr> <tr> <td>5</td> <td>IR</td> <td>0.500 kV</td> <td>2.50 MΩ</td> <td>-----</td> <td></td> </tr> <tr> <td></td> <td></td> <td></td> <td></td> <td>SCAN : 1 2 3 4 5 6 7 8</td> <td>F3</td> </tr> <tr> <td></td> <td></td> <td></td> <td></td> <td>SCAN : x x x x x x x x</td> <td>F4</td> </tr> <tr> <td></td> <td>PASS</td> <td>RMT</td> <td>LOCK</td> <td>OFST</td> <td>ERR</td> </tr> <tr> <td></td> <td></td> <td></td> <td></td> <td>MORE..</td> <td></td> </tr> </table>	VOLTAGE MEASURE REAL				OFFSET	F1	1	OS	0.055 kV	0.233 nF	----- P		2	AC	1.249 kV	0.08 mA	----- P		3	PA	CHANGE DUT		-----		4	DC	2.501 kV	0.000 mA	----- P		5	IR	0.500 kV	2.50 MΩ	-----						SCAN : 1 2 3 4 5 6 7 8	F3					SCAN : x x x x x x x x	F4		PASS	RMT	LOCK	OFST	ERR					MORE..		<p>F1 ◀ TURN OFFSET function OFF. F2 ◀ Perform OPEN/SHORT function. F3 F4 ◀ Press TWICE to return to STAND BY status</p>
	VOLTAGE MEASURE REAL				OFFSET	F1																																																								
	1	OS	0.055 kV	0.233 nF	----- P																																																									
	2	AC	1.249 kV	0.08 mA	----- P																																																									
3	PA	CHANGE DUT		-----																																																										
4	DC	2.501 kV	0.000 mA	----- P																																																										
5	IR	0.500 kV	2.50 MΩ	-----																																																										
				SCAN : 1 2 3 4 5 6 7 8	F3																																																									
				SCAN : x x x x x x x x	F4																																																									
	PASS	RMT	LOCK	OFST	ERR																																																									
				MORE..																																																										
TURN OFF OFFSET	<table border="1"> <tr> <td colspan="4">Turn off the offset function ?</td> <td></td> <td>F1</td> </tr> <tr> <td colspan="4">PRESS ENTER TO CONTINUE..</td> <td></td> <td>F2</td> </tr> <tr> <td></td> <td></td> <td></td> <td></td> <td>ENTER</td> <td>F3</td> </tr> <tr> <td></td> <td></td> <td></td> <td></td> <td>EXIT</td> <td>F4</td> </tr> <tr> <td></td> <td></td> <td>RMT</td> <td>LOCK</td> <td>OFST</td> <td>ERR</td> </tr> </table>	Turn off the offset function ?					F1	PRESS ENTER TO CONTINUE..					F2					ENTER	F3					EXIT	F4			RMT	LOCK	OFST	ERR	<p>F3 ◀ Turn OFF Offset Function</p>																														
	Turn off the offset function ?					F1																																																								
	PRESS ENTER TO CONTINUE..					F2																																																								
					ENTER	F3																																																								
				EXIT	F4																																																									
		RMT	LOCK	OFST	ERR																																																									
Test Setups	<table border="1"> <tr> <td colspan="4">VOLTAGE MEASURE REAL</td> <td>OFFSET</td> <td>F1</td> </tr> <tr> <td>1</td> <td>OS</td> <td>0.100 kV</td> <td>0.004 nF</td> <td>-----</td> <td></td> </tr> <tr> <td>2</td> <td>AC</td> <td>1.250 kV</td> <td>15.00 mA</td> <td>-----</td> <td></td> </tr> <tr> <td>3</td> <td>PA</td> <td>CHANGE DUT</td> <td></td> <td>-----</td> <td></td> </tr> <tr> <td>4</td> <td>DC</td> <td>2.500 kV</td> <td>0.500 mA</td> <td>-----</td> <td></td> </tr> <tr> <td>5</td> <td>IR</td> <td>0.500 kV</td> <td>2.50 MΩ</td> <td>-----</td> <td></td> </tr> <tr> <td></td> <td></td> <td></td> <td></td> <td>SCAN : 1 2 3 4 5 6 7 8</td> <td>F3</td> </tr> <tr> <td></td> <td></td> <td></td> <td></td> <td>SCAN : x x x x x x x x</td> <td>F4</td> </tr> <tr> <td></td> <td>STAND BY</td> <td>RMT</td> <td>LOCK</td> <td>OFST</td> <td>ERR</td> </tr> <tr> <td></td> <td></td> <td></td> <td></td> <td>MORE..</td> <td></td> </tr> </table>	VOLTAGE MEASURE REAL				OFFSET	F1	1	OS	0.100 kV	0.004 nF	-----		2	AC	1.250 kV	15.00 mA	-----		3	PA	CHANGE DUT		-----		4	DC	2.500 kV	0.500 mA	-----		5	IR	0.500 kV	2.50 MΩ	-----						SCAN : 1 2 3 4 5 6 7 8	F3					SCAN : x x x x x x x x	F4		STAND BY	RMT	LOCK	OFST	ERR					MORE..		<p>F4 ◀ Return to STAND BY status</p>
	VOLTAGE MEASURE REAL				OFFSET	F1																																																								
	1	OS	0.100 kV	0.004 nF	-----																																																									
	2	AC	1.250 kV	15.00 mA	-----																																																									
3	PA	CHANGE DUT		-----																																																										
4	DC	2.500 kV	0.500 mA	-----																																																										
5	IR	0.500 kV	2.50 MΩ	-----																																																										
				SCAN : 1 2 3 4 5 6 7 8	F3																																																									
				SCAN : x x x x x x x x	F4																																																									
	STAND BY	RMT	LOCK	OFST	ERR																																																									
				MORE..																																																										

If running the Open/Short Circuit Detection mode, perform Get Cs function after Offset but before exiting the MORE menu. Paragraph 2.12 illustrates the Get Cs menus.

2.12 GET Cs

GET Cs is applicable to the OS mode only. OS is normally programmed prior to an AC or DC hipot test to ensure the DUT is properly connected before the high voltage is applied. Refer to ¶2.4 for full explanation of the Open/Short Circuit check. The GET Cs function is illustrated herein using the pre-programmed example from ¶2.4-2.8 of the OS/AC/PA/DC/IR 5-step test.

After performing the OFFSET function, attach the known good DUT and press [F2] = GET Cs.

"STAND BY" Display with Memory ID	M01 STEP 1/5	OS	OPEN CHK: 50%	PROGRAM	F1			
	0.100kV 0.0nF 0.1s		SHORT CHK: 300%	PRESET	F2			
			SCAN : 1 2 3 4 5 6 7 8 : x x x x x x x x	MENU	F3			
		STAND BY	RMT	LOCK	OFST	ERR	MORE..	F4
Test Setups	VOLTAGE MEASURE REAL			OFFSET	F1			
	1 OS	0.100 kV	0.000 nF	-----	GET Cs	F2	◀ Perform OPEN/SHORT check.	
	2 AC	1.250 kV	15.00 mA	-----		F3		
	3 PA	CHANGE DUT		-----		F4	Return to STAND BY status	
	4 DC	2.500 kV	0.500 mA	-----				
	5 IR	0.500 kV	2.50 MΩ	-----	1 2 3 4 5 6 7 8 SCAN : x x x x x x x x			
	STAND BY	RMT	LOCK	OFST	ERR	MORE..	F4	Return to STAND BY status
GET Cs	1. Please connect the standard DUT.				F1			
	2. Get OFFSET before that.				F2	START ◀ To GET Cs value		
	3. Only OSC mode.				F3			
	PRESS START KEY TO GET Cs...				F4	Return to STAND BY status		
		RMT	LOCK	OFST	ERR	EXIT	F4	Return to STAND BY status
Test Setups	VOLTAGE MEASURE REAL			OFFSET	F1			
	1 OS	0.063 kV	0.004 nF	----- P	GET Cs	F2		
	2 AC	1.250 kV	15.00 mA	-----		F3		
	3 PA	CHANGE DUT		-----		F4	◀ Return to STAND BY status	
	4 DC	2.500 kV	0.500 mA	-----				
	5 IR	0.500 kV	2.50 MΩ	-----	1 2 3 4 5 6 7 8 SCAN : x x x x x x x x			
	PASS	RMT	LOCK	OFST	ERR	MORE..	F4	Return to STAND BY status

When GET Cs is complete, press [F4] = MORE to return to the Stand By menu.

2.13 Connection to Device under Test

Figure 2-9 illustrates the connection of the Guardian 1000 Series unit to a single DUT using the S02 1-meter HV cable set that comes standard with the instrument. The custom white banana plug/red alligator clip is connected between the OUTPUT terminal on the G1000 Series unit and the high side of the device under test. The black banana plug/alligator clip is connected between the RTN/LOW terminal on the G1000 Series unit to the low side of the DUT.

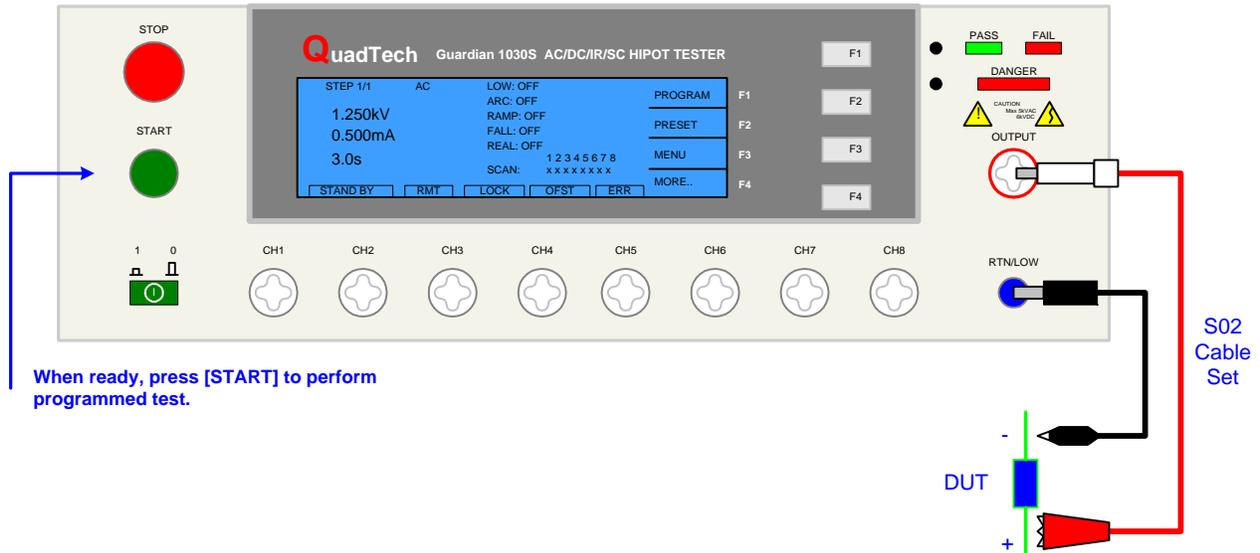

Figure 2-9: S02 Cable Connection

Figure 2-10 illustrates the connection of the Guardian 1000 Series unit to multiple devices for a SCAN test. The custom white banana plug/white wires are connected between the scan channels (CH1-8) designated as H (high) and the high side of the device under test. The black banana plug/alligator clip is connected between the RTN/LOW terminal on the G1000 Series unit to a common ground on the test fixture.

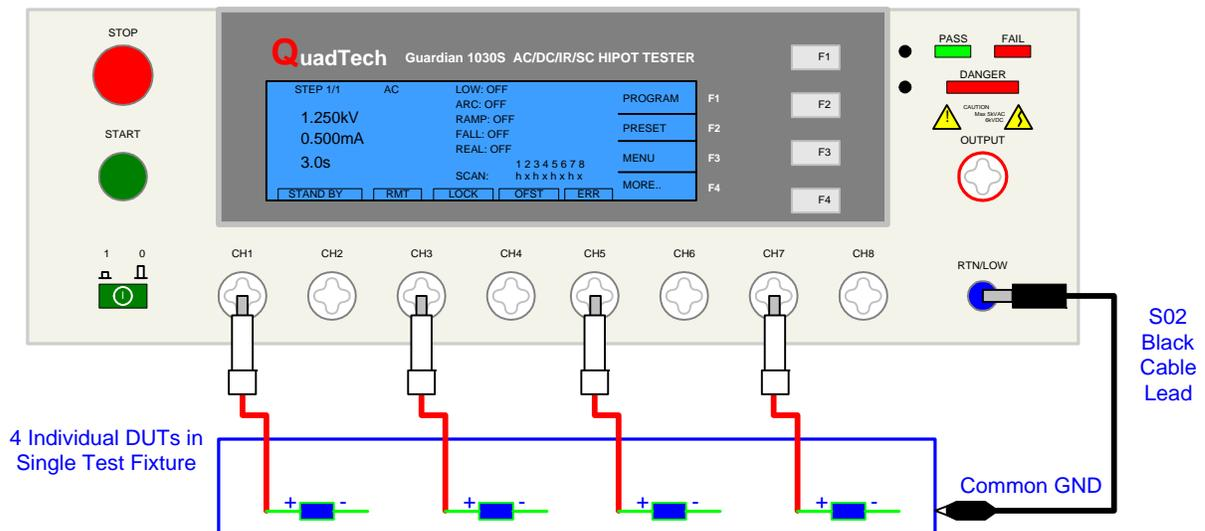

Figure 2-10: Scan Cable Connection

With the test fixture as shown in Figure 2-9, Channels 1, 3, 5 & 7 are designated H (high) and a common ground is connected between the RTN/LOW terminal on the G1000 unit and ground on the test fixture. In this case the Channels 2, 4, 6 & 8 would be designated X (not used). Another configuration for the scan test illustrated in Figure 2-9 is to assign Channels 2, 4, 6 & 8 as L (low) and connect a custom white banana plug between the channel and the low side of each of the four DUTs.

Refer to paragraphs 3.6 through 3.11 for the description and illustration of the connection of several QuadTech accessories to the Guardian 1000 Series instrument.

2.14 Measurement Procedure

Before a measurement is made verify the following:

1. Guardian 1000 Series instrument [POWER] ON.
2. 15-minute warm-up.
3. Test parameters programmed and shown on STAND BY display.
4. Test cables or fixture connected.
5. Offset Function initiated.
6. Device under test connected.

The operator has the option of performing a test at power-up conditions (test conditions at which the instrument was last powered down) or recalling one of 99 stored test setups. Refer to paragraphs 2.4 – 2.8 for test programming and storage/recall instructions.

To initiate a test:

Press [STOP] to make sure instrument is in STAND BY status.
Press [START]. DANGER led flashes. Status window shows UNDER TEST.
The test voltage is shut **off** when all test steps are completed,
OR when a test result is judged a FAIL per programmed test limits,
OR when the [STOP] button is pressed.
Press [STOP] at any time to terminate the output voltage and stop the test.

To view the test results, press [F4] = MORE to go to the tabular display. Use the UP/DOWN key to scroll to the next page. When “UUUU” is displayed as the result, it indicates that the unit has exceeded the upper measurement limit for leakage current or insulation resistance.

<p>NOTE: Exiting the tabular display will clear your test results.</p>

The Guardian 1000 Series instrument judges the measurement value as GOOD or NO GOOD. A GOOD judgment means the DUT passed all programmed steps. Upon completion of the test the output voltage is terminated and the display shows PASS. The rear panel PASS signal is functional and the buzzer sounds (if not turned OFF in SYSTEM parameters under MENU).

If the measurement value of the test (or any one step of the test) is abnormal, the DUT is judged as NO GOOD, the display will show FAIL and the buzzer will sound until the [STOP] button is pressed. Press [STOP] at any time to terminate the output voltage and stop the test.

Error Messages (FAIL result)

When the measurement value was judged NO GOOD and FAIL is shown on the display, an error message denoting the test result will be shown on the display also. Table 2-5 lists the possible error messages for a NO GOOD/FAIL judgment.

Table 2-5: Error Messages

Error Message	Description
HI	Measured value (current or resistance) is over the programmed high limit.
HI	Unit's output voltage is less than $(V_{\text{PROGRAM}} * 0.9) - 10\text{V}$
LO	Measured value (current or resistance) is below the programmed low limit.
ARC	Current arc is over the programmed high limit.
IO	Hardware failure: cannot detect test signal.
CHECK LOW	Charging current is over the low limit.
ADV OVER	Voltage/Current reading is greater than the allowable # of digits.
ADI OVER	Current/Resistance reading is greater than the allowable # of digits.
GR CONT.	Ground Continuity is No Good.
GFI NG	Ground Fault Interrupt is No Good.
AC REAL HI	Measured Real Current value is over the programmed high limit.

2.15 MENU Parameters

With the Guardian 1000 Series instrument in STAND BY status, press [F3] = MENU to access programmable instrument parameters. The MENU display contains the Memory, System, Option, Calibration, Key Lock, Change Password, Error Log and About functions. Table 2-6 lists these functions with description and default values.

Table 2-6: MENU Parameters

MENU #	Parameter	Function
1	MEMORY	Store, Recall or Delete a test setup from instrument memory
2	SYSTEM	Change display contrast; Change beeper volume; Enable DC 50V AGC
3	OPTION	Change RS232 settings: Change IEEE-488 address Change Print Options
4	CALIBRATION	Instrument calibration - Qualified service personnel only.
5	KEY LOCK	Lock out front panel program access.
6	CHANGE PASSWORD	Change key lock (user) password.
7	ERROR LOG	View status of error queue.
8	PRINT PROGRAM	Prints programmed test setup
9	ABOUT	Instrument Info: manufacturer, software version

2.15.1 MEMORY

Within the MEMORY menu is the ability to STORE, RECALL or DELETE test setups to and from instrument memory. There are 99 memory locations available that may contain 1-99 steps each. A caution here: instrument memory contains 500 slots; programming 99 steps and storing that into one memory location will bog down the instrument tremendously. It is wiser to program a smaller amount of test steps into more single memory locations; i.e. a 10-step test in location #1, a 5-step test in location #2, a 3-step test in location #3, etc. Recall the specific memory location when that set of tests is needed. **Note:** ¶2.10 illustrates the store function for the 5-step example used in this instruction manual.

2.15.1.1 STORE

To store a setup in memory, follow these instructions:

Press [F3] = MENU

The backlit box is next to 1. MEMORY

Press [F3] = SELECT to enter the MEMORY function.

Press [F1] = STORE to store preprogrammed test.

Press [F1] = UP or [F2] = DOWN to move the backlit box to the desired location.

Press [F3] = SELECT to choose backlit location.

Label location with a 0-13 alpha-numeric name:

Press [F1] = UP to select 1st character: 0-9, and A-Z.

Press [F3] = ENTER to move underscored cursor to next character.

Press [F1] = UP to select 2nd character: 0-9, and A-Z.

Press [F3] = ENTER to move underscored cursor to next character.

Press [F1] = UP to select 3rd character: 0-9, and A-Z.

Press [F3] = ENTER to move underscored cursor to next character.

Continue up to 13 characters

Press [F3] = ENTER twice when memory location label is complete.

Press [F4] = EXIT to exit MEMORY and return to MENU.

Press [F4] = EXIT to exit MENU and return to STAND BY.

2.15.1.2 RECALL

To recall a stored setup from memory, follow these instructions:

Press [F3] = MENU

The backlit box is next to 1. MEMORY

Press [F3] = SELECT to enter the MEMORY function.

Press [F2] = RECALL to enter RECALL function.

Press [F1] = UP or [F2] = DOWN to move the backlit box to the desired location.

Press [F3] = SELECT to choose backlit location.

Press [F1] = YES to recall backlit location.

Press [F4] = EXIT to exit MEMORY and return to MENU.

Press [F4] = EXIT to exit MENU and return to STAND BY.

2.15.1.3 DELETE

To delete a stored setup in memory, follow these instructions:

Press [F3] = MENU

The backlit box is next to 1. MEMORY

Press [F3] = SELECT to enter the MEMORY function.

Press [F3] = DELETE to enter DELETE function.

Press [F1] = UP or [F2] = DOWN to move the backlit box to the desired location.

Press [F3] = SELECT to choose backlit location.

Press [F1] = YES to delete backlit location.

Press [F4] = EXIT to exit MEMORY and return to MENU.

Press [F4] = EXIT to exit MENU and return to STAND BY.

2.15.2 SYSTEM

Within the SYSTEM menu are three programmable parameters: contrast, beeper volume and DC 50V AGC.

STAND BY	STEP 1/1	AC	LOW	:	OFF	PROGRAM	F1	
	1.250kV		ARC	:	OFF	PRESET	F2	
	15.00mA		RAMP	:	OFF	MENU	F3	Press F3 = "MENU" To change instrument parameters
	3.0s		FALL	:	OFF	MORE..	F4	
			REAL	:	OFF			
		SCAN	:	1 2 3 4 5 6 7 8 X X X X X X X X				
	STAND BY	RMT	LOCK	OFST	ERR			
MENU	1	MEMORY				LAST	F1	
	2	SYSTEM				DOWN	F2	Move backlit box down list
	3	OPTION				SELECT	F3	Enter SYSTEM parameters
	4	CALIBRATION				EXIT	F4	
	5	KEY LOCK						
	SELECT FUNC.	RMT	LOCK	OFST	ERR			
SYSTEM	1	CONTRAST	:	6		UP	F1	Change Contrast 1-16
	2	BEEPER VOL	:	OFF		DOWN	F2	Change Contrast 16-1
	3	DC 50V AGC	:	ON		NEXT	F3	Move backlit box to next parameter
						EXIT	F4	Return to MENU display
		1 - 16	RMT	LOCK	OFST	ERR		
SYSTEM	1	CONTRAST	:	6		UP	F1	Change Volume: HIGH/MED/LOW
	2	BEEPER VOL	:	OFF		DOWN	F2	Change Volume: HIGH/MED/LOW/OFF
	3	DC 50V AGC	:	ON		NEXT	F3	Move backlit box to next parameter
						EXIT	F4	Return to MENU display
		HIGH/MED/LOW	RMT	LOCK	OFST	ERR		
SYSTEM	1	CONTRAST	:	6		UP	F1	Turn DC 50V AGC ON/OFF
	2	BEEPER VOL	:	OFF		DOWN	F2	Turn DC 50V AGC ON/OFF
	3	DC 50V AGC	:	ON		NEXT	F3	Move backlit box to next parameter
						EXIT	F4	Return to MENU display
		ON/OFF	RMT	LOCK	OFST	ERR		

2.15.2.1 Contrast

The contrast parameter adjusts the brightness of the LCD display. The range is 1-16 with 16 being the darkest. The initial default setting is 6.

Press [F3] = MENU

Press [F2] = DOWN to move the backlit box to 2.

Press [F3] = SELECT to enter the SYSTEM function.

The backlit box is next to 1. CONTRAST:

Press [F1] = UP or [F2] = DOWN to increase/decrease the contrast of the display.

Press [F4] = EXIT to exit MEMORY and return to MENU.

Press [F4] = EXIT to exit MENU and return to STAND BY.

2.15.2.2 Beeper Volume

The beeper volume can be adjusted from low (soft) to medium (moderate) to high (loud) or it can be turned OFF. The initial default setting is high (loud).

Press [F3] = MENU

Press [F2] = DOWN to move the backlit box to 2.

Press [F3] = SELECT to enter the SYSTEM function.

Press [F2] = DOWN to move the backlit box to 2. BEEPER VOL.:

Press [F1] = UP or [F2] = DOWN to increase/decrease the volume of the alarm.

Press [F4] = EXIT to exit MEMORY and return to MENU.

Press [F4] = EXIT to exit MENU and return to STAND BY.

2.15.2.3 DC 50V AGC

The Automatic Gain Control (AGC) circuit is used to keep the output signal of a circuit constant as the amplitude of the input signal varies. So when the DC 50V AGC function is ON, the output voltage is held at a constant amplitude for the DC hipot test. The DC 50V AGC function can be set ON or OFF and the initial setting is ON.

NOTE:

Only in highly specialized applications should the DC 50V AGC function be set to OFF. The default value is ON because in normal test modes, it is necessary to keep the output signal constant as the amplitude of the input signal varies to obtain stable results.

Press [F3] = MENU

Press [F2] = DOWN to move the backlit box to 2.

Press [F3] = SELECT to enter the SYSTEM function.

Press [F2] = DOWN to move the backlit box to 3. DC 50V AGC.:

Press [F1] = UP or [F2] = DOWN to turn the DC automatic gain control circuit ON/OFF.

Press [F4] = EXIT to exit MEMORY and return to MENU.

Press [F4] = EXIT to exit MENU and return to STAND BY.

2.15.3 OPTION

Within the OPTION menu are three programmable parameters: RS232, GPIB and Print.

2.15.3.1 RS232

Within the RS232 menu there are three programmable parameters: baud rate, parity and flow control. The baud rate is adjustable as 300, 600, 1200, 2400 4800, 9600 or 19200 bps. The initial setting is 9600. The software flow control allows the RS232 interface to control the intake of data so the amount of data will not overload the I/O. Flow control of an RS232 interface is similar to DAV (Data is available and valid on data lines) on an IEEE interface.

Press [F3] = MENU

Press [F2] = DOWN to move the backlit box to 3.

Press [F3] = SELECT to enter the OPTION menu.

The backlit box is next to 1.

Press [F3] = SELECT to enter the RS232 menu.

The backlit box is next to 1. BAUD RATE:

Press [F1] = UP or [F2] = DOWN to enter the baud rate (300/600/1200/2400/4800/9600/19200)

Press [F3] = ENTER to move backlit box to 2. PARITY:

Press [F1] = UP or [F2] = DOWN to enter parity control as NONE, ODD or EVEN.

Press [F3] = ENTER to move backlit box to 3. FLOW CTRL:

Press [F1] = UP or [F2] = DOWN to enter the flow control as NONE or SOFTWARE.

Press [F4] = EXIT to exit OPTION and return to MENU.

Press [F4] = EXIT to exit MENU and return to STAND BY.

2.15.3.2 GPIB (IEEE-488)

Within the GPIB menu there is one programmable function: GPIB address. The range for the IEEE-488 address is 0-30 and the initial instrument setting is 3.

Press [F3] = MENU

Press [F2] = DOWN to move the backlit box to 3.

Press [F3] = SELECT to enter the OPTION menu.

Press [f2] = DOWN to move the backlit box is next to 2.

Press [F3] = SELECT to enter the IEEE-488 menu.

The backlit box is next to 1. GPIB ADDR.:

Press [F1] = UP or [F2] = DOWN to enter the address (0-30)

Press [F4] = EXIT to exit OPTION and return to MENU.

Press [F4] = EXIT to exit MENU and return to STAND BY.

2.15.3.3 PRINTER

Within the Printer menu there are seven programmable parameters: Pass, Fail, Part No., Lot No., Serial No., Test Data, and Result. These parameters can be set to ON or OFF. The initial setting is OFF.

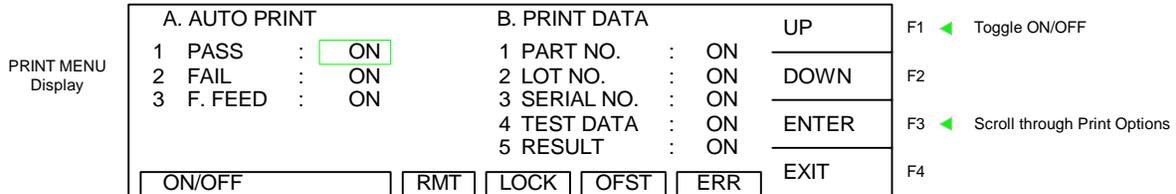

Figure 2-11: Print Option Menu

Press [F3] = MENU

Press [F2] = DOWN to move the backlit box to 3. OPTION

Press [F3] = SELECT to enter the OPTION menu.

Press [F2] = DOWN so that the backlit box is next to 3. PRINTER

Press [F3] = SELECT to enter the PRINTER menu.

The backlit box is next to 1. PASS: ON

Press [F1] = UP to turn Auto Print on Pass ON or OFF

Press [F3] = ENTER to move backlit box to 2. FAIL: ON

Press [F1] = UP to turn Auto Print on Fail ON or OFF.

Press [F3] = ENTER to move backlit box to 3. F. FEED: ON

Press [F1] = UP to turn the Form Feed function ON or OFF.

Press [F3] = ENTER to move backlit box to 1. PART NO: ON

Press [F1] = UP to turn the Print Part Number function ON or OFF.

Press [F3] = ENTER to move backlit box to 2. LOT NO: ON

Press [F1] = UP to turn the Print Lot Number function ON or OFF.

Press [F3] = ENTER to move backlit box to 3. SERIAL NO: ON

Press [F1] = UP to turn the Print Serial Number function ON or OFF.

Press [F3] = ENTER to move backlit box to 4. TEST DATA: ON

Press [F1] = UP to turn the Print Test Data function ON or OFF.

Press [F3] = ENTER to move backlit box to 5. RESULT: ON

Press [F1] = UP to turn the Print Result function ON or OFF.

Press [F4] = EXIT to exit OPTION and return to MENU.

Press [F4] = EXIT to exit MENU and return to STAND BY.

Auto Print Functions:

These two functions are used to determine when print data is desired. Both Pass and Fail can be turned ON to obtain data from all tests.

Pass: When selected ON, the G1000 will send data to the printer when the test result is a Pass.

Fail: When selected ON, the G1000 will send data to the printer when the test result is a Fail.

F. Feed: When selected ON, the printer paper will automatically form feed at the end of the print out. This is used when one test result is desired per a page. If the printer is being used to log data and multiple tests are desired per a page, F. Feed should be set to OFF.

Print Data Functions:

These functions are used to determine what data is to be printed.

- Part No.:** When selected ON, the part number entered in the Preset section will print.
- Lot No.:** When selected ON, the lot number entered in the Preset section will print
- Serial No.:** When selected ON, the serial number entered in the Preset section will print
- Test Data:** When selected ON, the step #, mode, output voltage, measured current and result will print.
- Result:** When selected ON, the final Pass/Fail of all steps will print

Refer to paragraph “3.4 Printer Interface” for detail of print out.

2.15.4 CALIBRATION

The CALIBRATION function requires a password to enter the instrument routine. Only qualified service personnel with NIST traceable standards should perform instrument calibration. Refer to paragraph 4.3 for the Guardian 1000 Series calibration procedure.

2.15.5 KEY LOCK

To lock out the PROGRAM and PRESET functions of the Guardian 1000 Series instrument use the KEY LOCK function in the MENU parameters. The range of KEY LOCK is ON or OFF and the initial instrument setting is OFF. To activate the KEY LOCK function:

Press [F3] = MENU

Press [F2] = DOWN until **KEY LOCK** is backlit.

Press [F3] = SELECT

Display prompts ‘PASSWORD’

Press [A] [A] [A] [A] [ENTER]

NOTE: AAAA is the default password. If password has been changed use the new password.

Display prompts ‘RECALL LOCK: YES’

Press [F1] = YES to select KEY LOCK ON.

NOTE: Selecting YES disallows the recalling of programmed tests from memory.

The **LOCK** block at bottom of display is backlit.

Press [F4] = EXIT to return to STAND BY status.

PROGRAM and PRESET are no longer visible or functional.

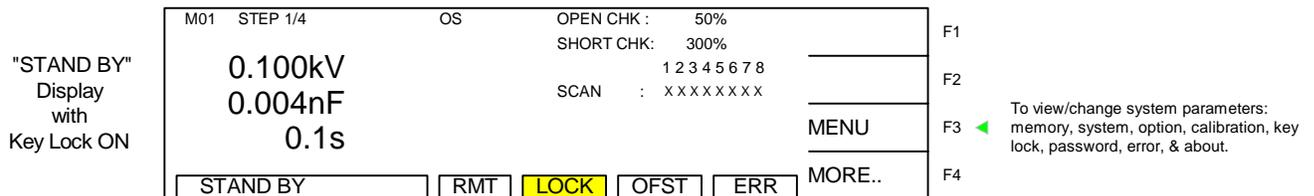

Figure 2-12: Key Lock Display

To disable the KEY LOCK function, repeat above steps.

2.15.6 CHANGE PASSWORD

The Guardian 1000 Series instruments have a password function for locking out the front panel so that the instrument PRESET settings and PROGRAM function are disabled. A separate password is used to perform instrument calibration. Refer to paragraph 4.3. The CHANGE PASSWORD function applies to the initial instrument password. To activate the CHANGE PASSWORD function:

Press [F3] = MENU

Press [F2] = DOWN until **CHANGE PASSWORD** is backlit.

Press [F3] = SELECT

Display prompts 'PASSWORD'

Press [A] [A] [A] [A] [ENTER]

Display prompts 'NEW PASSWORD'

Press [B] [B] [B] [B] [ENTER]

Display prompts 'CONFIRM'

Press [B] [B] [B] [B] [ENTER]

Display prompts 'CHANGE PASSWORD OK!! PRESS EXIT TO CONTINUE'

2.15.7 ERROR LOG

The Guardian 1000 Series instruments have an Error Log to track communication errors when the IEEE-488 interface or RS232 interface is being used. Refer to paragraph 3.3.5 and Table 3-5 for a list of error message numbers and their respective description. When the **ERR** block on the bottom of the display is backlit, there is an error message in the queue. To view the contents of the error log:

Press [F3] = MENU

Press [F2] = DOWN until **ERROR LOG** is backlit.

Press [F3] = SELECT

Display lists the contents of the Error Log.

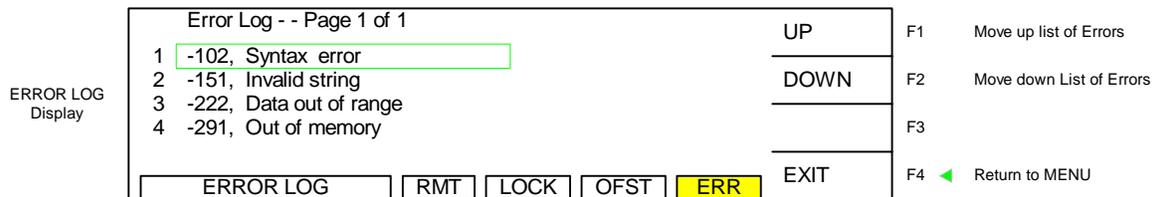

Figure 2-13: ERROR LOG Display

The queue will clear itself once the log has been viewed.

2.15.8 PRINT PROGRAM

When the G38 printer card is installed in the G1000 Series instrument, then this option can be selected. When F3 “Select” is pressed, the Guardian 1000 Series instrument will send the programmed test setup to the printer. Refer to paragraph 3.4 “Printer Interface” for detail of the print out.

Press [F3] = MENU

Press [F2] = DOWN until **PRINT PROGRAM** is backlit.

Press [F3] = SELECT

Display lists the Print Option Menu. Refer to paragraph 2.15.3.3.

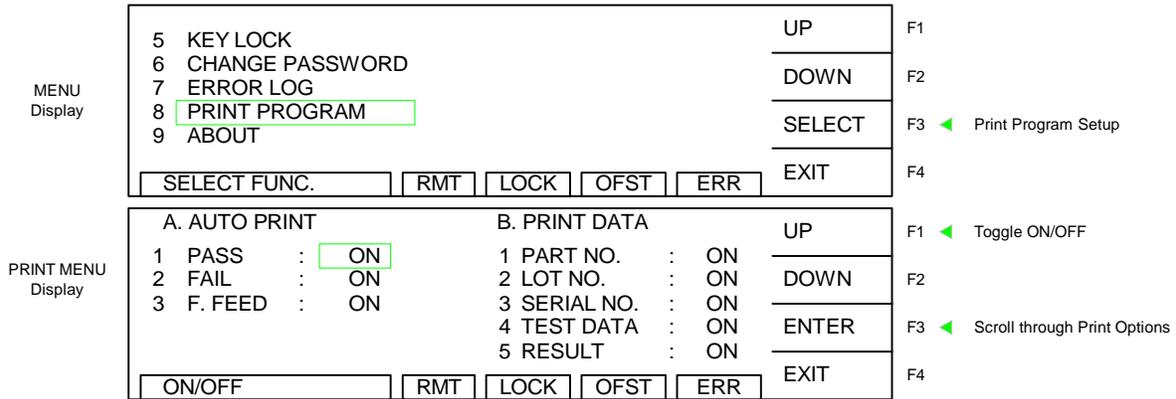

Figure 2-14: Select Print Program

2.15.9 ABOUT

The Guardian 1000 Series instruments have a parameter labeled ‘About’. This parameter lists the instrument manufacturer, software version and date. To view the contents of ABOUT:

Press [F3] = MENU

Press [F2] = DOWN until **ABOUT** is backlit.

Press [F3] = SELECT

Display lists the contents of ABOUT.

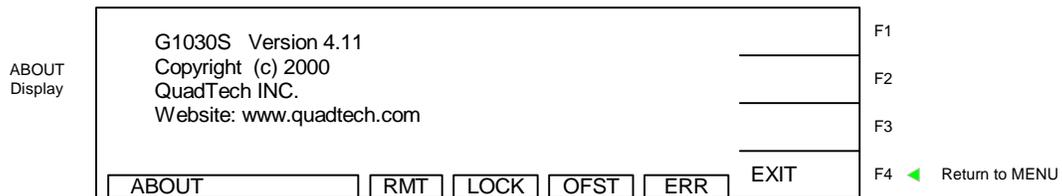

Figure 2-15: ABOUT Display

Section 3: Interface

3.1 Remote

A 9-pin D-Series remote control connector is located on the rear panel of the Guardian 1000 Series instrument. There is a black 11 screw terminal strip for the remote output signals: UNDER TEST, PASS & FAIL and the remote inputs: START, RESET, COM AND INTERLOCK.

Inputs require a contact closure and outputs provide a contact closure. Figure 3-1 illustrates the Remote terminal strip connector and 9-pin D-Series connector.

Before connecting the instrument to its power source, the interlock function on the rear panel remote connector (terminal strip) must be properly utilized. This is an important safety feature for the protection of the operator. When the INTERLOCK jumper is removed, there is **no** high voltage at the OUTPUT. Therefore, to initiate a test make sure the interlock jumper is in place.

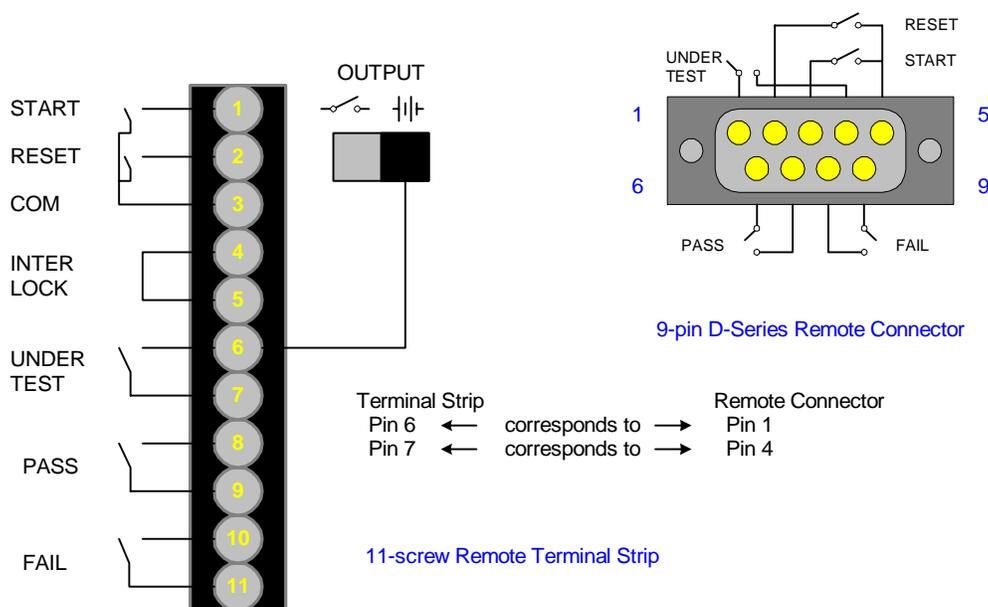

Figure 3-1: Guardian 1000 Series Remote Connectors

The Guardian 1000 Series instrument has three output signals on the rear panel. When the OUTPUT switch is in open (switch open), the UNDER TEST relay is closed during a test. The PASS relay is closed when the DUT is judged GOOD. The FAIL relay is closed when the DUT is judged NO GOOD. These relays are rated for voltage up to 115VAC and current <0.3A. When the OUTPUT switch is in the battery signal position, 24VDC 100mA output is present on both UNDER TEST terminals when the unit is in STAND BY mode. When the unit is testing, 24VDC is present only on the bottom (#7) UNDER TEST terminal.

Figures 3-2 and 3-3 illustrate possible remote control connections to the Guardian 1000 Series terminal strip. Use extreme care when using a remote control connection as the High Voltage Output is being turned ON and OFF with an external signal.

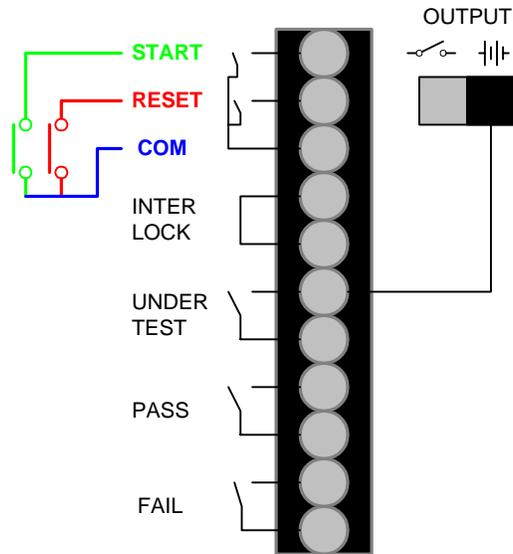

Figure 3-2: Single Control of START or RESET

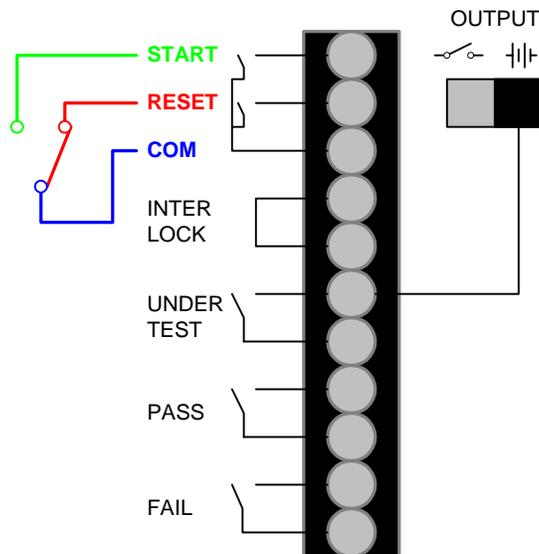

Figure 3-3: Continuous Control of RESET

START and RESET terminals have unregulated 24VDC present. To initiate a test connect the START and COM terminals. To terminate a test connect the RESET and COM terminals.

Figure 3-4 illustrates the timing diagram for the Guardian 1000 Series instruments under a PASS condition and a FAIL condition.

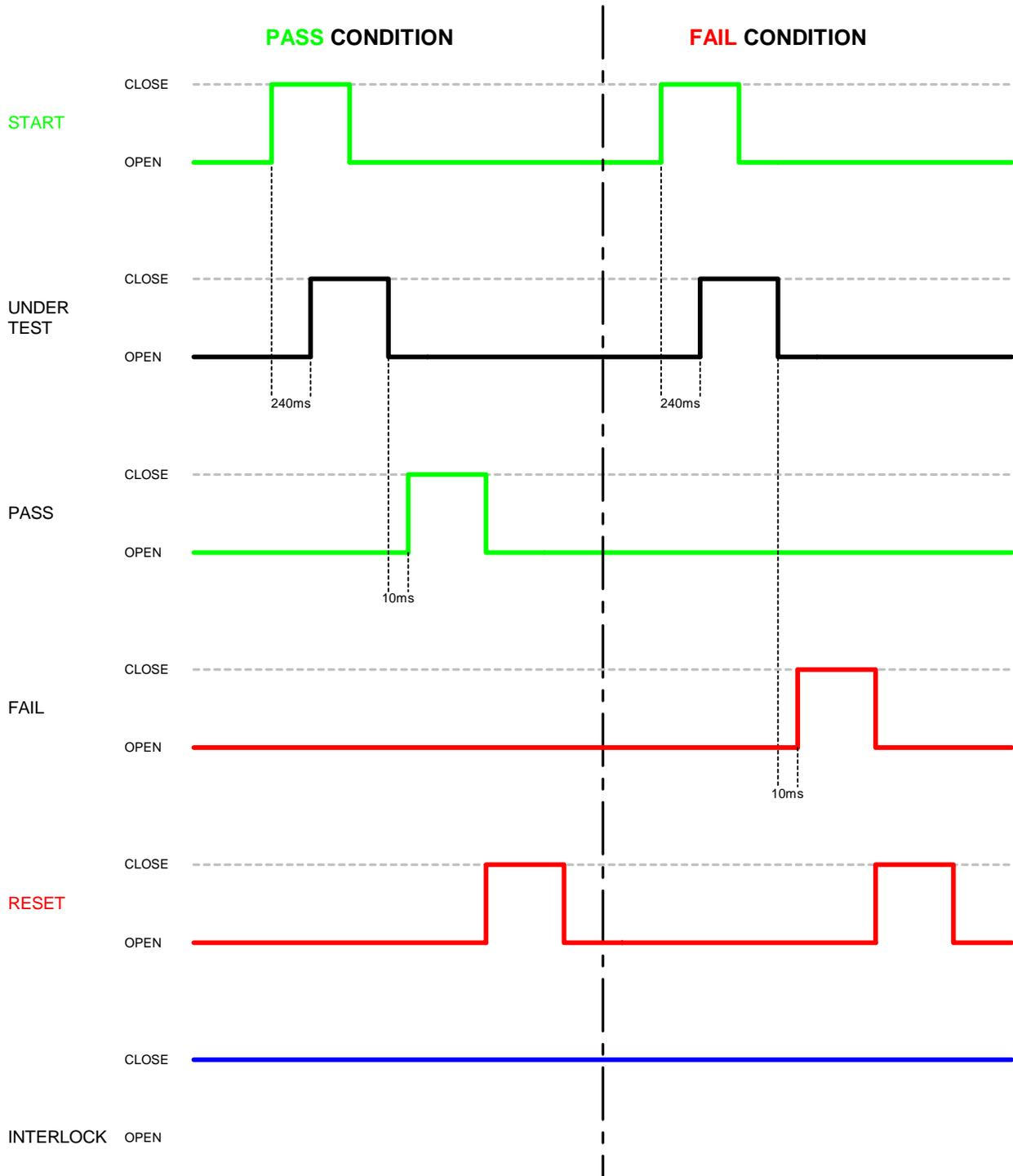

Figure 3-4: Guardian 1000 Series Timing Diagram

3.2 RS232 Interface

3.2.1 Pin Configuration

The Guardian 1000 Series instruments all come standard with an RS232 Interface for remote operation. Connection is through the silver 9-pin connector labeled 'RS232' on the rear panel of the Guardian 1000 Series instrument. Figure 3-5 illustrates the designation of the pins on the RS232 connector. The connection cable must be a 'straight through' cable for the G1000 series unit to communicate.

NOTE

When the RS232 Interface and the IEEE-488 Interface are both installed in a Guardian 1000 Series instrument, only **one** of the two interfaces may be activated at a time.

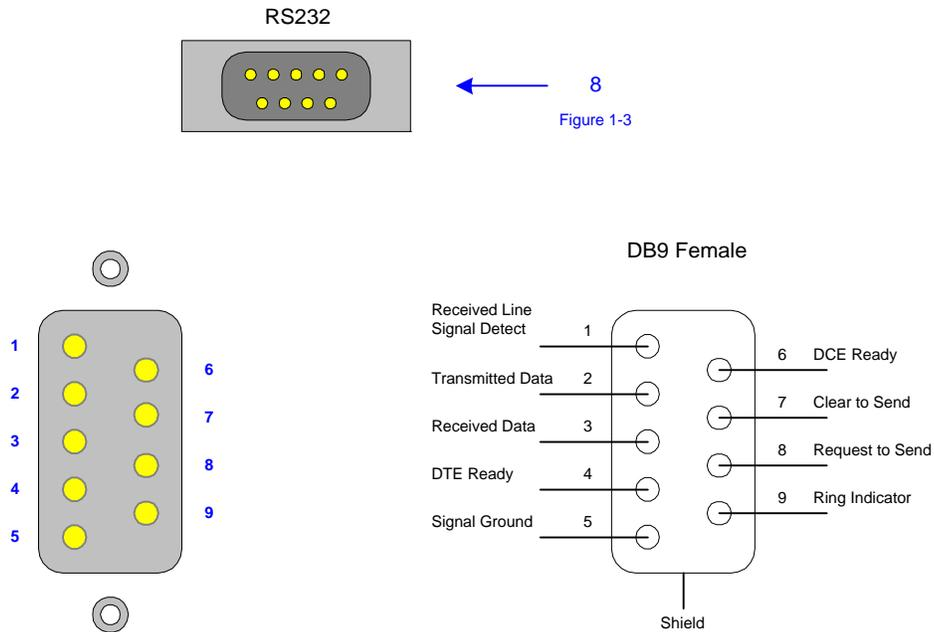

Figure 3-5: RS232 Pin Configuration

When the **ERR** box is backlit on the bottom of the display, there are error messages in the queue. Refer to paragraph 3.3.5, Table 3-7 for explanation of error messages. Refer to paragraph 2.15.7 for instructions on how to access and clear the error log.

3.2.2 RS232 Specifications

Data Bits: 8
Stop Bits: 1
Parity: None, Odd, Even
Baud Rate: 0.3/0.6/1.2/2.4/4.8/9.6/19.2(k) Software selectable
EOS: LF or CR + LF
Echo: Off

Selecting the Baud Rate, Parity and Flow Control

Setting the Baud Rate is done in the OPTION function under MENU settings:

From the STAND BY display, press [F3] = MENU.
Press [F2] = DOWN two times to highlight **OPTION**.
Press [F3] = SELECT to enter OPTION function.
Press [F3] = SELECT to select RS232 function.
Display shows “1. BAUD RATE : **9600**” with rate highlighted.
Press [F1] = UP to select baud rate.
Press [F4] to EXIT

OR

Press [F3] = ENTER to change the parity.
Display shows “2. PARITY : **ODD**” with parity bit highlighted.
Press [F1] = UP to select parity.
Press [F4] to EXIT

OR

Press [F3] = ENTER to change the flow control.
Display shows “3. FLOW CTRL. : **NONE**” with parity bit highlighted.
Press [F1] = UP to select software flow control or no flow control.
Press [F4] to EXIT

The software flow control allows the RS232 interface to control the intake of data so the amount of data will not overload the I/O. Flow control of an RS232 interface is similar to DAV (Data is available and valid on data lines) on an IEEE interface.

3.2.3 RS232 Commands

The command set for the RS232 interface is the same as the IEEE-488 interface command set listed in paragraphs 3.3.3 through 3.3.5 of this instruction manual.

NOTE

CR + LF are necessary end codes for the RS232 commands.

There are additional RS232 only commands on the following page.

Additional RS232 Commands

Some commands for RS232 use only are listed here. These commands follow the SCPI version 1999.0.

```
:SYSTem:LOCK:RELease ==> Change statue to local, as GPIB Go To Local.  
:SYSTem:LOCK:REQuEst? ==> Change statue to Remote, return '1' if successful.  
:SYSTem:LOCK:OWNEr? ==> Query the statue.  
:SYSTem:LOCK <Boolean> ==> As GPIB Local Lockout.  
:SYSTem:LOCK? ==> Query the Key Lock status.
```

3.2.4 Sample QuickBasic Program

```
REM Guardian 1000 series RS232 example program  
REM Created using Quick Basic  
  
REM open serial port as device 1  
OPEN "COM2:9600,N,8,1,RS," FOR RANDOM AS #1  
CLS  
  
REM Send STOP command to device  
PRINT #1, "SOURce:SAFEty:STOP"; CHR$(13); CHR$(10)  
  
REM Ask device how many steps are programed  
PRINT #1, "SOURce:SAFEty:SNUMBer?"; CHR$(13); CHR$(10)  
  
INPUT #1, SNUMBer  
REM Loop to delete any programed steps  
IF SNUMBer > 0 THEN  
    FOR I = SNUMBer TO 0 STEP -1  
        IF I = 0 GOTO Program  
        temp$ = INPUT$(LOC(1), 1)  
        PRINT #1, "SOURce:SAFEty:STEP", I, ":DELeTe"; CHR$(13); CHR$(10)  
    NEXT I  
END IF  
  
Program:  
PRINT "Programing G1000"  
REM Program STEP 1 for AC HIPOT  
REM Program AC test voltage for 1000 V  
PRINT #1, "SOURce:SAFEty:STEP1:AC:LEVEl 1000"; CHR$(13); CHR$(10)  
  
REM Program high current limit for 6 mA  
PRINT #1, "SOURce:SAFEty:STEP1:AC:LIMit:HIGH 0.006"; CHR$(13); CHR$(10)  
  
REM Program test time for 5 seconds  
PRINT #1, "SOURce:SAFEty:STEP1:AC:TIME:TEST 5.0"; CHR$(13); CHR$(10)
```

REM Program Low current limit off
PRINT #1, "SOURce:SAFEty:STEP1:AC:LIMit:LOW 0.0000"; CHR\$(13); CHR\$(10)

REM Program ARC limit for 0.9 mA
PRINT #1, "SOURce:SAFEty:STEP1:AC:LIMit:ARC:LEVEl 0.0009"; CHR\$(13);
CHR\$(10)

REM Program ramp time for 4 seconds
PRINT #1, "SOURce:SAFEty:STEP1:AC:TIME:RAMP 4.0"; CHR\$(13); CHR\$(10)

REM Program Real Current limit for 3 mA
PRINT #1, "SOURce:SAFEty:STEP1:AC:LIMit:REAL 0.0030"; CHR\$(13); CHR\$(10)

REM Program STEP 2 for DC HIPOT
REM Program DC test voltage for 1000 V
PRINT #1, "SOURce:SAFEty:STEP2:DC:LEVEl 1000"; CHR\$(13); CHR\$(10)

REM Program high current limit for 7 mA
PRINT #1, "SOURce:SAFEty:STEP2:DC:LIMIT:HIGH 7e-3"; CHR\$(13); CHR\$(10)

REM Program test time for 4 seconds
PRINT #1, "SOURce:SAFEty:STEP2:DC:TIME 4"; CHR\$(13); CHR\$(10)

REM Program low current limit for off
PRINT #1, "SOURce:SAFEty:STEP2:DC:LIMit:LOW 0.0000"; CHR\$(13); CHR\$(10)

REM Program Arc limit for 1 mA
PRINT #1, "SOURce:SAFEty:STEP2:DC:limit:ARC:LEVEl 0.001"; CHR\$(13);
CHR\$(10)

REM Program ramp time for 2 seconds
PRINT #1, "SOURce:SAFEty:STEP2:DC:TIME:RAMP 2.0"; CHR\$(13); CHR\$(10)

REM Program STEP 3 for IR Test

REM Program IR DC voltage for 100 V
PRINT #1, "SOURce:SAFEty:STEP3:IR:LEVEl 100"; CHR\$(13); CHR\$(10)

REM Program low resistance limit for .4 Mohm
PRINT #1, "SOURce:SAFEty:STEP3:IR:LIMIT:LOW 400000"; CHR\$(13); CHR\$(10)

REM Program test time for 5 sec
PRINT #1, "SOURce:SAFEty:STEP3:IR:TIME 5"; CHR\$(13); CHR\$(10)

REM Program high resistance limit off

```

PRINT #1, "SOURce:SAFEty:STEP3:IR:LIMit:HIGH 0.000"; CHR$(13); CHR$(10)

REM Program ramp time off
PRINT #1, "SOURce:SAFEty:STEP3:IR:TIME:RAMP 0.0"; CHR$(13); CHR$(10)

PRINT #1, "SOURce:SAFEty:SNUMBer?"; CHR$(13); CHR$(10)

INPUT #1, STEPNUM%
CLS
REM Start TEST
PRINT #1, "SOURce:SAFEty:START"; CHR$(13); CHR$(10)
PRINT " Testing"
REM Check status of the test
complete$ = "0"
WHILE complete$ <> "1"
  PRINT #1, "SOURce:SAFEty:RESult:COMplete?"; CHR$(13); CHR$(10)
  INPUT #1, complete$
  CLS
  IF complete$ = "1" THEN
    PRINT #1, "SOURce:SAFEty:STOP"; CHR$(13); CHR$(10)

    REM Print Output voltage for each step
    PRINT #1, "SAFEty:RESult:ALL:OMET?"; CHR$(13); CHR$(10)

    FOR j = 1 TO STEPNUM%
      INPUT #1, RESult$
      PRINT "Measured Output Voltage:"
      PRINT "step", j, ":", RESult$

    NEXT j
    PRINT
    PRINT "*****"
    REM Print Measured result for each step
    PRINT #1, "SAFEty:RESult:ALL:MMET?"; CHR$(13); CHR$(10)
    FOR j = 1 TO STEPNUM%
      INPUT #1, RESult$
      PRINT "Measured Result:"
      PRINT "step", j, ":", RESult$
    NEXT j
  END IF

WEND
PRINT #1, "SOURce:SAFEty:STOP"; CHR$(13); CHR$(10)
CLOSE #1
END

```

3.3 IEEE-488 Interface

3.3.1 Pin Configuration

The Guardian 1000 Series instrument has an optional IEEE-488 interface that is factory installed when the instrument is ordered. Connection is through the blue 24-pin connector labeled ‘GPIB’ on the rear panel of the Guardian 1000 Series instrument. This interface can be used to connect a system containing a number of instruments and a controller in which each meets IEEE Standard 488.2 (Standard Digital Interface for Programmable Instrumentation). Figure 3-6 illustrates the designations of the pins on the IEEE-488 connector.

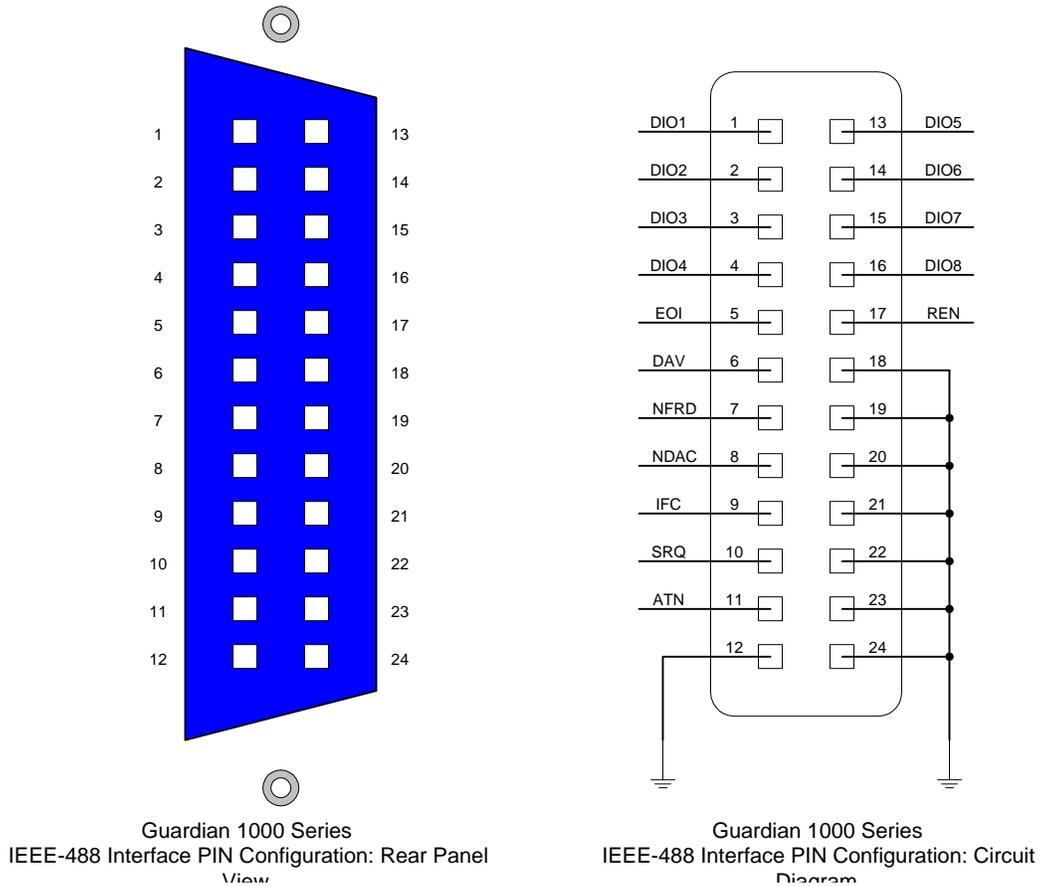

Figure 3-6: IEEE-488 Interface Pin Configuration

Table 3-1 lists the IEEE-488 Interface pin designations by pin number, signal name and pin function.

Table 3-1: IEEE-488 Interface Pin Designations

Signal Name	Pin Number	Function
DAV	6	Low State: "Data is Available" and valid on DI01 through DI08
NRFD	7	Low State: At least one Listener on the bus is "Not Ready For Data"
NDAC	8	Low State: At least one Listener on the bus is "Not Accepting Data"
ATN	11	"Attention" specifies 1 of 2 uses for the DI01 through DI08 lines: Low State: Controller command messages High State: Data bytes from the Talker device
IFC	9	"Interface Clear" Low State: Returns portion of interface system to a known quiescent state
SRQ	10	"Service Request" Low State: A Talker or Listener signals (to the controller) need for attention in the midst of the current sequence of events.
REN	17	"Remote Enable" Low State: Enables each device to enter remote mode when addressed to listen. High State: All devices revert to Local control.
EOI	5	"End of Identify" If ATN is in HIGH state, then EOI LOW state indicates the end of a multiple-byte data transfer sequence. If ATN is in LOW state, then EOI LOW state indicates a parallel poll.
DI01	1	The 8-Line Data Bus. If ATN is in LOW state, then the bus conveys interface messages. If ATN is in HIGH state, then the bus conveys device-dependent messages. (Example: carries remote control commands from the controller or from a talker device)
DI02	2	
DI03	3	
DI04	4	
DI05	13	
DI06	14	
DI07	15	
DI08	16	

3.3.2 IEEE-488 Interface Codes and Messages

The IEEE-488 (GPIB) address is defined under the MAIN MENU in the OPTION MENU. Press [MAIN MENU] then the numerical key [2] to enter the OPTION MENU. Press function key [F2] to enter the GPIB SETUP menu. To select a new IEEE-488 address, use the function keys

The Guardian 1000 Series unit is in a remote control status when the RMT block on the bottom right hand side of display is backlit.

To switch to Local from Remote press the [LOCAL] key, disabled by LLO message.

Table 3-2 defines the IEEE-488 interface codes and their function. Table 3-3 defines the IEEE-488 interface messages and their function.

Table 3-2: IEEE-488 Interface Functions

Code	Function
SH1	Source Handshake
AH1	Acceptor Handshake
T4	Basic Talker Function
L4	Basic Listener Function
SR1	Service Request Function
RL1	All Remote/Local Function
PP0	No Parallel Poll Function
DC1	All Device Clear Function
DT0	Device Trigger Function
C0	No Controller Functions

Table 3-3: IEEE-488 Interface Messages

Interface Message	Function	Description
GTL	Go To Local	Switch unit to local
SDC	Selected Device Clear	Reset the unit
LLO	Local Lockout	Disables [LOCAL] switch to local
IFC	Interface Clear	Reset IEEE-488 bus interface

3.3.3 IEEE-488 Interface Commands

The interface function is controlled by ASCII commands that include:

{[command + parameter] ; [command + parameter] + ending code}

The maximum string length is consists of 1024 characters. It is not necessary to input any sign or space between the command and parameter. Any two commands can be connected by "," and [Ending Code]. Ending Code can be any type in Table 3-4.

Table 3-4: IEEE-488 Interface Ending Codes

Ending Code
LF
CR + LF
EOI
LF + EOI
CR + LF + EOI

NOTE

The data can be sent out by the IEEE-488 interface to achieve transfer function. The data command is {string message + ending code}. The ending codes are in Table 3-4.

NOTE

CR + LF are necessary ending codes for the RS232 Commands.

3.3.3.1 IEEE-488 Register Assignments

Table 3-5 lists the bit assignments for the Summary and Event registers. The configuration of these registers is illustrated in Figure 3-7.

Table 3-5: Summary Status & Event Status Registers

Summary Status Register			Event Status Register		
Bit	Decimal Value	Use	Bit	Decimal Value	Use
0	1	Not Used	0	1	Operation Complete
1	2	Has Result	1	2	Not Used
2	4	Error/Event Queue	2	4	Query Error
3	8	Not Used	3	8	Device Error (No device contact)
4	16	Message Available	4	16	Execution Error (Over Range, etc.)
5	32	Summary Standard Event Status Register	5	32	Command Error (Syntax)
6	64	Request Service	6	64	Not Used
7	128	Not Used	7	128	Power ON

3.3.3.2 IEEE-488 Register Configuration

Figure 3-7 illustrates the configuration of the Summary (Status), Event and Enable Registers for the Guardian 1000 Series IEEE-488 Interface.

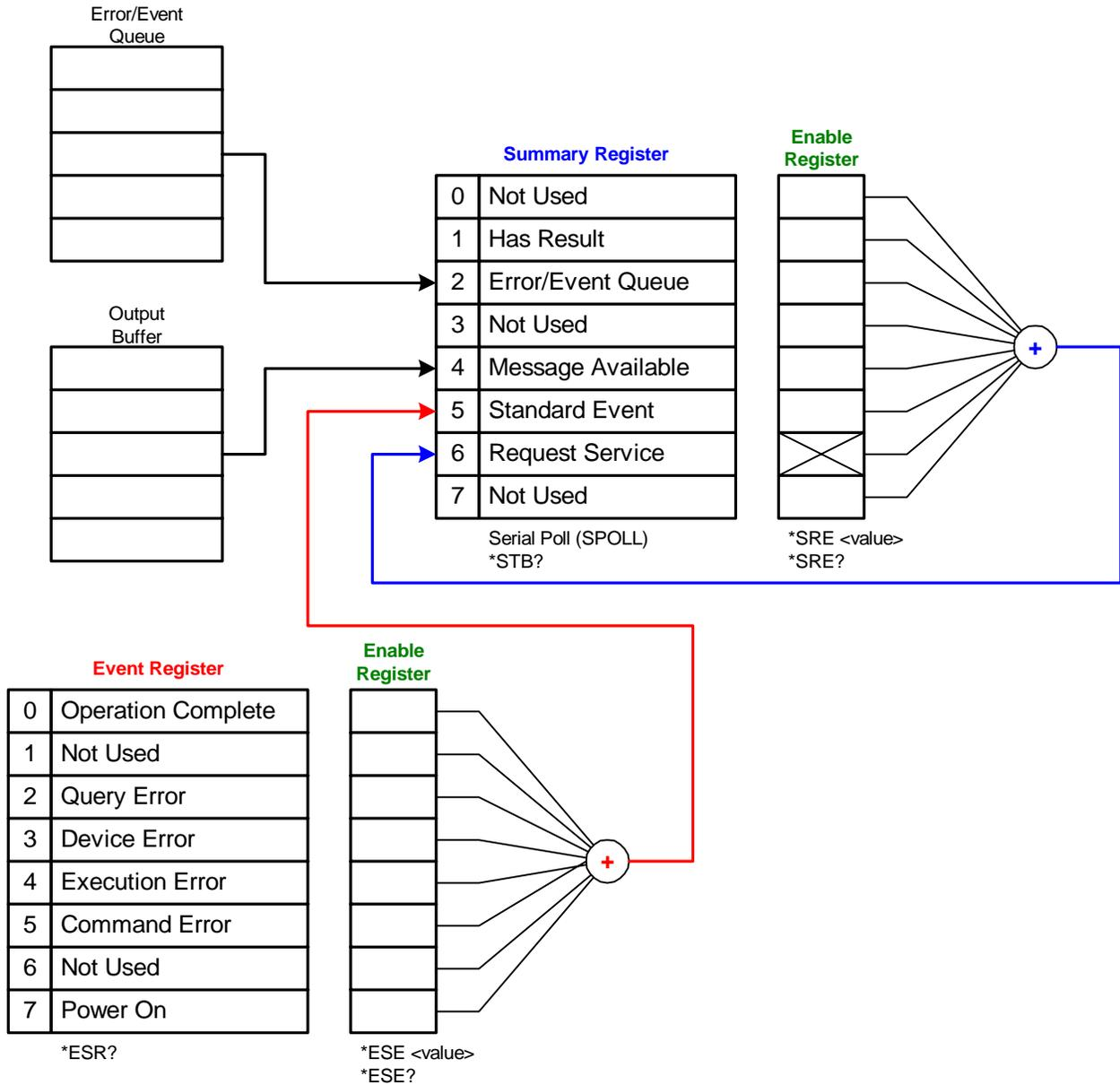

Figure 3-7: Guardian 1000 Series IEEE-488 Register Configuration

Table 3-6: IEEE-488 Commands

Command	Name	Function	Output Format
*CLS	Clear Status	Clear standard event status register. Clear status bit group register except for bit 4 (MAV)	
*ESE	Event Status Enable	Enable standard event status register value.	0 – 255
*ESE?	Event Status Enable	Query standard event status of device enable register	0 – 255
*ESR?	Event Status Register	Query standard event register value of device. After this command, the standard register is cleared to 0.	0 – 255
*SRE	Service Request Enable	Enable service request register value.	0 – 255
*SRE?	Service Request Enable	Query/Read service request register value.	0 – 255
*STB?	Status Byte Register	Query/Read status byte register value	0 – 255
*OPC	Operation Complete	Operation is complete.	
*OPC?	Operation Complete	Query operation complete.	1
*PSC 0 1	Power On	Clear status of Power On	
*PSC?	Power On	Query Power On.	1 or 0
*IDN?	Identification	Query/Read basic device data. (A comma separates the identification fields.)	4 ID: Manufacturer, Device Model, Serial Number, Firmware Version
*SAV	Save	Save current status to memory.	1 – 99
*RCL	Recall	Recall saved status from memory.	1 – 99

3.3.4 IEEE-488 & SCPI Command Summary

The SCPI (Standard Commands for Programmable Instruments) parameter syntax format is listed on the following pages. To illustrate the order of precedence the entire command list is scrolled through. The dual arrow symbol “<>” denotes the defined parameter is a standard SCPI command. The symbol “<numerical value>” denotes the metric system value. The symbol “<boolean>” denotes the Boolean equation data and its value is 0 or 1. The vertical line “|” denotes the OR parameter. When sending the G1000 series unit a decimal number it is necessary to have a zero before the decimal point. Example: DC: LIMit: HIGH: 0.004

:SYSTem

:VERSion?

Command: :SYSTem : VERSion?

This command queries the SCPI version of this device.

:ERRor

Command: :SYSTem : ERRor?

This command reads the message in the Error Queue.

Refer to paragraph 3.3.5 for Error Messages

:LOCK

:REQuest?1

Command: :SYSTem : LOCK : REQuest?1

This command locks the front panel (disables start from front panel).

:RELease

Command: :SYSTem : LOCK : RELease

This command unlocks the front panel (enables start from front panel).

:KLOCK1

Command: :SYSTem : KLOCK1

This command locks local controls.

:MEMory

:STATe

:DEFine <name>, Location

Command: :MEMory : STATe : DEFine NAME, LOCATION

This command saves setup with name and location.

:LABEl <register name>

Command: :MEMory : STATe : LABEl ? <register number>

This command queries the memory location name.

Note: if location name is ABC, response is “ABC”. If no location name, response is “”.

:DELete

:NAME <name>

Command: :MEMory : DELete : NAME

This command deletes the data in main memory under defined name.

:FREE

:STEP?

Command: MEMory : FREE : STEP?

This command queries the next free step in main memory.

:PRESet?

Command: :MEMory : FREE : PRESet?

This command queries the next free preset number in main memory.

:SOURCE

:SAFETY

:START

Command: :SOURCE : SAFETY : START

This command starts the test.

:OFFSet GET | OFF

Command: :SOURCE : SAFETY : START : OFFSet GET

This command gets the offset value.

Command: : SOURCE : SAFETY : START : OFFSet OFF

This command turns the offset function off.

:OFFSet?

Command: : SOURCE : SAFETY : START : OFFSet?

This command queries if the offset function is ON or OFF.

:CSTANDARD

Command: :SOURCE : SAFETY : START : CSTANDARD

This command get Cs value for OSC mode.

:STOP

Command: :SOURCE : SAFETY : STOP

This command stops the test.

:STATus?

Command: :SOURCE : SAFETY : STATus?

This command queries the execution status of the current device under test.

The return character data is RUNNING | STOPPED

:RESult

:ALL

:JUDGment?

Command: :SOURCE : SAFETY : RESult : ALL : JUDGment?

This command queries all the judgment results.

The return format is:

PASS	74	116
USER STOP	71	113
CAN NOT TEST	72	114
TESTING	73	115
STOP	70	112

	AC MODE		DC MODE		IR MODE	
	HEX	DEC	HEX	DEC	HEX	DEC
HI	11	17	21	33	31	49
LO	12	18	22	34	32	50
ARC	13	19	23	35	33	---
IO	14	20	24	36	34	52
Check Low	---	---	25	37	---	---
ADV OVER	16	22	26	38	36	54
ADI OVER	17	23	27	39	37	55
REAL HIGH	1a	26	---	---	---	---
GR CONT.	78	120	78	120	78	120
GFI	79	121	79	121	79	121

:OMETerage?

Command: :SOURce : SAFETy : RESult : ALL : OMETerage?

This command queries all the voltage (output meter) readings for the step.

:MMETerage?

Command: :SOURce : SAFETy : RESult : ALL : MMETerage?

This command queries all the Measure Meter readings for the step.

:RMETerage?

Command: :SOURce : SAFETy : RESult : ALL : RMETerage?

This command queries all the Real Current Meter readings for the step.

:TIME :TEST?

Command: :SOURce : SAFETy : RESult : ALL : TIME : TEST?

This command reads back all step test times including failure times.

:LAST :JUDGment?

Command: :SOURce : SAFETy : RESult : LAST : JUDGment?

This command queries status while testing.

:RESult**:COMPleted?**

Command: :SOURce : SAFETy : RESult : COMPlete?

This command queries if all the test results are completed.

The return format is a "1" or a "0".

:AREPort <Boolean> ON | OFF (RS232 Interface only)

Command: :SOURce : SAFETy : RESult : AREPort

This command sets the Automatic Reporting of the test results.

:AREPort ? (RS232 Interface only)

Command: :SOURce : SAFETy : RESult : AREPort?

This command queries if the Automatic Reporting of test results is ON or OFF.

The return format is a "1" or a "0".

:SNUMber?

Command: :SOURce : SAFETy : SNUMber?

This command queries the step number being set in memory.

:STEP <n>**:DELeTe**

Command: :SOURce : SAFETy : STEP : DELeTe

This command clears all setting values in selected step to the initial value.

<n> denotes the step number. Range: $1 \leq n \leq 99$.

:SET?

Command: :SOURce : SAFETy : STEP : SET?

This command queries all setting values in selected step.

:MODE?

Command: :SOURce : SAFETy : STEP <n> : MODE?

This command queries the test Mode of the selected step.

The return format is: AC | DC | IR.

<numeric value> 0, 1 – 5 (1 = 100%, 5 = 500%)

:OSC

:LIMIT

:OPEN <numeric value>

Command: :SOURCE:SAFETY:STEP<n>:OSC:LIMIT:OPEN

This command sets the Open circuit percentage

<numeric value> 0.5 to 1 (0.5 = 50%)

:SHORT <numeric value>

Command: :SOURCE:SAFETY:STEP<n>:OSC:LIMIT:SHORT

This command sets the Short circuit percentage

:STEP <n>

:AC

:LEVEL <numeric value>

Command: :SOURCE : SAFETY : STEP <n> : AC : LEVEL

This command sets the AC voltage level for the selected step.

<numeric value> is 50 to 5000 and the unit is volts.

:LEVEL?

Command: :SOURCE : SAFETY : STEP <n> : AC : LEVEL?

This command queries the AC voltage level for the selected step.

The return format is a numerical value: $50 \leq \text{value} \leq 5000$ volts.

:LIMIT

:HIGH <numeric value>

Command: :SOURCE : SAFETY : STEP <n> : AC : LIMIT : HIGH

This command sets the high current limit for the selected step.

<numeric value> is 0.000001 to 0.030 and the unit is amps.

:HIGH?

Command: :SOURCE : SAFETY : STEP <n> : AC : LIMIT : HIGH?

This command queries the high current limit for the selected step.

:REAL: HIGH <numeric value>

Command: :SOURCE : SAFETY : STEP <n> : AC : LIMIT : REAL : HIGH

This command sets the high limit for real current. Valid for AC Hipot test only.

<numeric value> is 0.000001 to 0.030 and the unit is amps. 0 = OFF

:REAL?

Command: :SOURCE : SAFETY : STEP <n> : AC : LIMIT : REAL : HIGH?

This command queries the high limit for the real current test.

:LOW <numeric value>

Command: :SOURCE : SAFETY : STEP <n> : AC : LIMIT : LOW

This command sets the low current limit for the selected step.

<numeric value> is 0 to 0.030 and the unit is amps. 0 = OFF

:LOW?

Command: :SOURCE : SAFETY : STEP <n> : AC : LIMIT : LOW?

This command queries the low current limit for the selected step.

:ARC <numeric value>

Command: :SOURCE : SAFETY : STEP <n> : AC : LIMIT : ARC

This command sets the arc current limit for the selected step.

<numeric value> is 0 to 0.030 and the unit is amps. 0 = OFF

:ARC?

Command: :SOURce : SAFETY : STEP <n> : AC : LIMit : ARC?
This command queries the arc current limit for the selected step.

:TIME

:RAMP <numeric value>

Command: :SOURce : SAFETY : STEP <n> : AC : TIME : RAMP

This command sets the ramp time for the selected step.

<numeric value> is 0, 0.1 to 999 and the unit is seconds. 0 = OFF

:RAMP?

Command: :SOURce : SAFETy : STEP <n> : AC : TIME : RAMP?
This command queries the ramp time for the selected step.

:TEST <numeric value>

Command: :SOURce : SAFETy : STEP <n> : AC : TIME : TEST
This command sets the test time for the selected step.
<numeric value> is 0, 0.3 to 999 and the unit is seconds. 0 = OFF

:TEST?

Command: :SOURce : SAFETy : STEP <n> : AC : TIME : TEST?
This command queries the test time for the selected step.

:FALL <numeric value>

Command: :SOURce : SAFETy : STEP <n> : AC : TIME : FALL
This command sets the fall time for the selected step.
<numeric value> is 0 to 999 and the unit is seconds. 0 = OFF

:FALL?

Command: :SOURce : SAFETy : STEP <n> : AC : TIME : FALL?
This command queries the fall time for the selected step.

:CHANnel (@ <1> (<channel list>))

:HIGH <channel list>

Command: :SOURce : SAFETy : STEP <n> : AC : CHANnel : HIGH (@ 1 (<channel list>))
This command sets the high scan channels for the selected step.

:HIGH?

Command: :SOURce : SAFETy : STEP <n> : AC : CHANnel : HIGH?
This command queries the high scan channels for the selected step.

:LOW <channel list>

Command: :SOURce : SAFETy : STEP <n> : AC : CHANnel : LOW (@ 1 (<channel list>))
This command sets the low scan channels for the selected step.

:LOW?

Command: :SOURce : SAFETy : STEP <n> : AC : CHANnel : LOW?
This command queries the low scan channels for the selected step.

Example:

The command :SOURce : SAFETy : STEP 1 : AC : CHANnel : HIGH (@ 1 (1:4))
Sets Channels 1 through 4 HIGH.

NOTE: Channel list must be 0 (zero) when no channels are set high or low.

Example: to turn a Channel OFF, proceed as follows:

:SOURce : SAFETy : STEP 1 : AC : CHANnel : HIGH (@ 1 (0))
Sets the channel that is currently HIGH to OFF.

:SOURce : SAFETy : STEP 1 : AC : CHANnel : LOW (@ 1 (0))
Sets the channel that is currently LOW to OFF.

:DC

:LEVel <numeric value>

Command: :SOURce : SAFETy : STEP <n> : DC : LEVel

This command sets the DC voltage level for the selected step.

<numeric value> is 50 to 6000 and the unit is volts.

:LEVel?

Command: :SOURce : SAFETy : STEP <n> : DC : LEVel?

This command queries the AC voltage level for the selected step.

The return format is a numerical value: $50 \leq \text{value} \leq 6000$ volts.

:LIMit

:HIGH <numeric value>

Command: :SOURce : SAFETy : STEP <n> : DC : LIMit : HIGH

This command sets the high current limit for the selected step.

<numeric value> is 0.0000001 to 0.010 and the unit is amps.

:HIGH?

Command: :SOURce : SAFETy : STEP <n> : DC : LIMit : HIGH?

This command queries the high current limit for the selected step.

:LOW <numeric value>

Command: :SOURce : SAFETy : STEP <n> : DC : LIMit : LOW

This command sets the low current limit for the selected step.

<numeric value> is 0 to 0.010 and the unit is amps. 0 = OFF

:LOW?

Command: :SOURce : SAFETy : STEP <n> : DC : LIMit : LOW?

This command queries the low current limit for the selected step.

:ARC <numeric value>

Command: :SOURce : SAFETy : STEP <n> : DC : LIMit : ARC

This command sets the arc current limit for the selected step.

<numeric value> is 0 to 0.010 and the unit is amps. 0 = OFF

:ARC?

Command: :SOURce : SAFETy : STEP <n> : DC : LIMit : ARC?

This command queries the arc current limit for the selected step.

:TIME

:RAMP <numeric value>

Command: :SOURce : SAFETy : STEP <n> : DC : TIME : RAMP

This command sets the ramp time for the selected step.

<numeric value> is 0 to 999 and the unit is seconds. 0 = OFF

:RAMP?

Command: :SOURce : SAFETy : STEP <n> : DC : TIME : RAMP?

This command queries the ramp time for the selected step.

:TEST <numeric value>

Command: :SOURce : SAFETy : STEP <n> : DC : TIME : TEST

This command sets the test time for the selected step.

<numeric value> is 0, 0.3 to 999 and the unit is seconds. 0 = Continuous

:TEST?

Command: :SOURce : SAFETy : STEP <n> : DC : TIME : TEST?

This command queries the test time for the selected step.

:FALL <numeric value>

Command: :SOURce : SAFETy : STEP <n> : DC : TIME : FALL

This command sets the fall time for the selected step.

<numeric value> is 0 to 999 and the unit is seconds. 0 = OFF

:FALL?

Command: :SOURce : SAFETy : STEP <n> : DC : TIME : FALL?

This command queries the fall time for the selected step.

:CHANnel (@ <1> (<channel list>))

:HIGH <channel list>

Command: :SOURce : SAFETy : STEP <n> : DC : CHANnel : HIGH (@1 (<channel list>))

This command sets the high scan channels for the selected step.

:HIGH?

Command: :SOURce : SAFETy : STEP <n> : DC : CHANnel : HIGH?

This command queries the high scan channels for the selected step.

:LOW <channel list>

Command: :SOURce : SAFETy : STEP <n> : DC : CHANnel : LOW (@1(<channel list>))

This command sets the low scan channels for the selected step.

:LOW?

Command: :SOURce : SAFETy : STEP <n> : DC : CHANnel : LOW?

This command queries the low scan channels for the selected step.

NOTE: Channel list must be 0 (zero) when no channels are set high or low.

:IR

:LEVel <numeric value>

Command: :SOURce : SAFETy : STEP <n> : IR : LEVEL

This command sets the DC voltage level for the selected step.

<numeric value> is 50 to 1000 and the unit is volts.

:LEVel?

Command: :SOURce : SAFETy : STEP <n> : IR : LEVEL?

This command queries the AC voltage level for the selected step.

The return format is a numerical value: $50 \leq \text{value} \leq 1000$ volts.

:LIMit

:HIGH <numeric value>

Command: :SOURce : SAFETy : STEP <n> : IR : LIMit : HIGH

This command sets the high resistance limit for the selected step.

<numeric value> is 0 to 50G and the unit is ohms. 0 = OFF

:HIGH?

Command: :SOURce : SAFETy : STEP <n> : IR : LIMit : HIGH?

This command queries the high current limit for the selected step.

:LOW <numeric value>

Command: :SOURce : SAFETy : STEP <n> : IR : LIMit : LOW

This command sets the low resistance limit for the selected step.

<numeric value> is 0.1 to 50000M and the unit is ohms.

:LOW?

Command: :SOURce : SAFETy : STEP <n> : IR : LIMit : LOW?

This command queries the low current limit for the selected step.

:TIME

:RAMP <numeric value>

Command: :SOURce : SAFETy : STEP <n> : IR : TIME : RAMP

This command sets the ramp time for the selected step.

<numeric value> is 0 to 999 and the unit is seconds. 0 = OFF

:RAMP?

Command: :SOURce : SAFETy : STEP <n> : IR : TIME : RAMP?

This command queries the ramp time for the selected step.

:TEST <numeric value>

Command: :SOURce : SAFETy : STEP <n> : IR : TIME : TEST

This command sets the test time for the selected step.

<numeric value> is 0, 0.3 to 999 and the unit is seconds. 0 = Continuous

:TEST?

Command: :SOURce : SAFETy : STEP <n> : IR : TIME : TEST?

This command queries the test time for the selected step.

:FALL <numeric value>

Command: :SOURce : SAFETy : STEP <n> : IR : TIME : FALL

This command sets the fall time for the selected step.

<numeric value> is 0 to 999 and the unit is seconds. 0 = OFF

:FALL?

Command: :SOURce : SAFETy : STEP <n> : IR : TIME : FALL?

This command queries the fall time for the selected step.

:CHANnel (@ <1> (<channel list>))

:HIGH <channel list>

Command: :SOURce : SAFETy : STEP <n> : IR : CHANnel : HIGH (@ 1 (<channel list>))

This command sets the high scan channels for the selected step.

:HIGH?

Command: :SOURce : SAFETy : STEP <n> : IR : CHANnel : HIGH?

This command queries the high scan channels for the selected step.

:LOW <channel list>

Command: :SOURce : SAFETy : STEP <n> : IR : CHANnel : LOW (@ 1 (<channel list>))

This command sets the low scan channels for the selected step.

:LOW?

Command: :SOURce : SAFETy : STEP <n> : IR : CHANnel : LOW?

This command queries the low scan channels for the selected step.

NOTE:

Channel list must be 0 (zero) when no channels are set high or low.

:PRESet

:KEYboard : SMART

Command: :SOURce : SAFETy : PRESet : KEYboard : SMART?

This command queries if the Smart Key function is ON or OFF.

Command: :SOURce : SAFETy : PRESet : KEYboard : SMART <boolean> | ON | OFF

This command turns the Smart Key function ON or OFF.

:TIME

:PASS <numerical value>

Command: :SOURce : SAFETy : PRESet : TIME : PASS

This command sets the time the pass relay on the remote I/O is closed when result is pass.
<numeric value> is a value between 0.2 and 99.9 and the unit is seconds.

:PASS?

Command: :SOURce : SAFETy : PRESet : TIME : PASS?

This command queries the set time for the pass relay on the remote I/O to be closed.

:STEP <numerical value> | KEY

Command: :SOURce : SAFETy : PRESet : TIME : STEP

This command sets the interval time between steps.

<numeric value> is a value or character key between 0.1 and 99.9 seconds.

:STEP?

Command: :SOURce : SAFETy : PRESet : TIME : STEP?

This command queries the interval time between tests.

:JUDGment <numerical value>

Command: :SOURce : SAFETy : PRESet : TIME : JUDGment

This command sets the time between measurement and judgment.

<numeric value> is a value between 0.1 and 99.9 and the unit is seconds.

:JUDGment?

Command: :SOURce : SAFETy : PRESet : TIME : JUDGment?

This command queries the time between measurement and judgment.

:AC

:FREQuency <numerical value>

Command: :SOURce : SAFETy : PRESet : AC : FREQuency

This command sets the test frequency for AC Hipot Test.

<numeric value> is a value between 50 and 600 and the unit is Hz.

:FREQuency?

Command: :SOURce : SAFETy : PRESet : AC : FREQuency?

This command queries the test frequency for the AC Hipot Test.

:WRANge

:AUTO <boolean> ON | OFF

Command: :SOURce : SAFETy : PRESet : WRANge : AUTO

This command sets the Auto Range function ON or OFF.

<boolean value> is a "1" or a "0".

:AUTO?

Command: :SOURce : SAFETy : PRESet : WRANge : AUTO?

This command queries the status of the Auto Range function.

The return value is a "1" or a "0".

:AGC

:SOFTware <boolean> ON | OFF

Command: :SOURce : SAFETy : PRESet : AGC : SOFTware

This command sets the software Automatic Gain Control function ON or OFF.

<boolean value> is a "1" or a "0".

:SOFTware?

Command: :SOURce : SAFETy : PRESet : AGC : SOFTware?

This command queries the status of the software Automatic Gain Control function.

The return value is a “1” or a “0”.

:GCONTinuity <boolean> ON | OFF

Command: :SOURce : SAFETy : PRESet : GCONTinuity

This command sets the Ground Continuity Check function ON or OFF.

<boolean value> is a “1” or a “0”.

:GCONTinuity?

Command: :SOURce : SAFETy : PRESet : GCONTinuity?

This command queries if the Ground Continuity Check function ON or OFF.

The return value is a “1” or a “0”.

:GFI <boolean> ON | OFF

Command: :SOURce : SAFETy : PRESet : GFI

This command sets the Ground Fault Interrupt function to OFF or ON.

GFI?

Command: :SOURce : SAFETy : PRESet : GFI?

This command queries the status of the Ground Fault Interrupt function.

The return character is “0” or “1”.

0 = OFF and 1 = ON

:FCONtin

Command: :SOURce : SAFETy : PRESet : FCONtin ON

This command turns the Continue on Fail function ON.

Command: :SOURce : SAFETy : PRESet : FCONtin OFF

This command turns the Continue on Fail function OFF.

:NUMBER**:PART <numerical value>**

Command: :SOURce : SAFETy : PRESet : NUMBER : PART

This command sets the part number for the device under test.

<numeric value> is a value between 0.2 and 99.9.

:PART?

Command: :SOURce : SAFETy : PRESet : NUMBER : PART?

This command queries the part number of the device under test.

:LOT <numerical value>

Command: :SOURce : SAFETy : PRESet : NUMBER : LOT

This command sets the lot number for the device under test.

<numeric value> is a value between 0.2 and 99.9.

:LOT?

Command: :SOURce : SAFETy : PRESet : NUMBER : LOT?

This command queries the lot number of the device under test.

:SERIal <numerical value>

Command: :SOURce : SAFETy : PRESet : NUMBER : SERIal

This command sets the serial number format.

<numeric value> is a value between 0.2 and 99.9.

:SERIal?

Command: :SOURce : SAFETy : PRESet : NUMBER : SERIal?

This command queries the serial number format.

3.3.5 Error Messages

Error messages are saved in an error queue that is accessed by the FIFO method. The first return error message is the first saved in the queue. When the error message queue is over 30 messages, the error message “Queue overflow” will be displayed. The error queue cannot save any more error messages until this queue is cleared. When there is no error in the queue, the first position in the queue displays “No error”. Table 3-7 lists the error messages by number and description. When the **ERR** box is backlit on the bottom of the display, there are error messages in the queue.

Table 3-7: IEEE-488 Error Messages

#	Type	Description
-102	Syntax Error	Command includes a prohibited character or symbol
-108	Parameter Not Allowed	Device received a prohibited parameter
-109	Missing Parameter	Parameter missing from programming
-112	Mnemonic Too Long	Command program header is > 12 characters
-113	Undefined Header	Device received undefined header.
-114	Header Suffix Out of Range	Header suffix is out of range
-151	Invalid String of Data	Invalid string (usually missing double quotation marks)
-158	String Not Allowed	Data string is not allowed
-170	Expression Error	Device received incomplete parameter data
-222	Data Out of Range	Data is out of range
-291	Out of Memory	No memory left
-292	Referenced Name	Queried a name that does not exist
-293	Referenced Name	Cannot save a name that already exists
-361	Parity Error	Wrong parity in program message
-363	Input Buffer Overrun	Device received over 1024 characters
-365	Time Out Error	Device did not receive end character within certain time
-400	Queue Error	Output queue data is > 256 characters
-410	Query Interrupted	Query interrupted because query result from previous query has not yet been read.
-420	Query Terminated	Query terminated because the output queue data cannot be read when there is NO data in the queue.

3.3.6 Sample IEEE-488 Basic Programs

Included herein are two sample Basic programs. The first will program and run a two-step test and print the results. The second will program a two-step test and save it to G1000 instrument memory. This second program also adds two additional test steps, stores them in a second memory location then recalls first memory location for test.

```
REM-----
REM  G1000 IEEE sample program
REM  Please run the ULI file before this program.
REM  GPIB address is 3
REM-----

REM  This sample will program and run a two step test.
REM  Step 1 is a DC Hipot test at 1000 V
REM  Step 2 is an AC Hipot test at 1000 V
REM  The results of the test will be printed

CLS
PRINT "Program is running"
OPEN "gpib0" FOR OUTPUT AS #1
OPEN "gpib0" FOR INPUT AS #2
PRINT #1, "abort"
PRINT #1, "GPIBEOS IN LF"
PRINT #1, "Remote 03"

REM Send Stop command to G1000
PRINT #1, "output 3;:SOURce:SAFEty:STOP"
REM Ask G1000 how many steps are currently programmed
PRINT #1, "output 3;:SOURce:SAFEty:SNUMBer?"
PRINT #1, "enter 3"
INPUT #2, STEPNUM%

REM Delete programmed steps
PRINT "DELETE STEPS"

IF STEPNUM% > 0 THEN
  FOR I = STEPNUM% TO 1 STEP -1
    PRINT #1, "output 3;:SOURce:SAFEty:STEP", I, ":DELeTe"
  NEXT I
END IF

CLS
REM Program Tester
PRINT "PROGRAM STEPS"

REM Program Step 1 DC test voltage 1 for 1000 V
PRINT #1, "output 3;:SOURce:SAFEty:STEP 1:DC 1000"

REM Program high current limit for 0.4 mA
PRINT #1, "output 3;:SOURce:SAFEty:STEP 1:DC:LIMit:HIGH 0.0004"

REM Program Test time for 2 seconds
PRINT #1, "output 3;:SOURce:SAFEty:STEP 1:DC:TIME 2"
```

```

REM Program Step 2 AC test voltage for 1000 V
PRINT #1, "output 3;:SOURce:SAFEty:STEP 2:AC 1000"

REM Program high current limit for 0.2 mA
PRINT #1, "output 3;:SOURce:SAFEty:STEP 2:AC:LIMit 0.0002"

REM Program test time for 3 seconds
PRINT #1, "output 3;:SOURce:SAFEty:STEP 2:AC:TIME:TEST 3"

REM Send stop command to G1000
PRINT #1, "output 3;:SOURce:SAFEty:STOP"

REM Send start command to G1000
PRINT #1, "output 3;:SOURce:SAFEty:START"

REM Check status of G1000
complete$ = "0"
WHILE complete$ <> "1"
  PRINT #1, "output 3;:SAFEty:RESult:COMplete?"
  PRINT #1, "enter 3"
  INPUT #2, complete$

  IF complete$ = "1" THEN
    PRINT #1, "output 3;:SOURce:SAFEty:STOP"
    PRINT #1, "output 3;:SAFEty:RESult:ALL:OMET?"
    PRINT #1, "enter 3"

    FOR j = 1 TO STEPNUM%
      INPUT #2, result$
      PRINT "Measured Output Voltage"
      PRINT "step", j, ":", result$
    NEXT j

    PRINT

    PRINT #1, "output 3;:SAFEty:RESult:ALL:MMET?"
    PRINT #1, "enter 3"

    FOR j = 1 TO STEPNUM%
      INPUT #2, result$
      PRINT "Measured Result"
      PRINT "step", j, ":", result$
    NEXT j
  END IF
WEND

PRINT #1, "output 3;:SOURce:SAFEty:STOP"
CLOSE : SYSTEM
END

```

```

REM -----
REM  G1000 IEEE Sample Program 2
REM  Please run the ULI file before this program
REM  G1000 GPIB address is 3
REM -----
REM This program will set a two step AC hipot test and save it to
REM Memory location 1. It will then add two additional steps and
REM save it to Memory location 3. Finally it will recall Memory
REM location 1.
REM ****In order for this program to function the way it was
REM ****intended be sure there are no steps present in the
REM ****standby mode before running this program

OPEN "gpib0" FOR OUTPUT AS #1
OPEN "gpib0" FOR INPUT AS #2

PRINT #1, "abort"
PRINT #1, "GPIBEOS IN LF"
PRINT #1, "output 3;SOURce:SAFETy:STOP"
PRINT #1, "output 3;SOURce:SAFETy:STEP1:AC:LEVel 600"
PRINT #1, "output 3;SOURce:SAFETy:STEP1:AC:LIMit:HIGH 0.0004"

PRINT #1, "output 3;SOURce:SAFETy:STEP2:AC:LEVel 500"
PRINT #1, "output 3;SOURce:SAFETy:STEP2:AC:LIMit:HIGH 0.0003"

REM Save programed steps to memory location 1 and label it ACAC
PRINT #1, "output 3;*SAV 1"
PRINT #1, "output 3;MEMory:STATE:DEFine ACAC,1"

PRINT #1, "output 3;SOURce:SAFETy:STEP3:DC:LEVel 700"
PRINT #1, "output 3;SOURce:SAFETy:STEP3:DC:LIMit:LOW 0.0001"

PRINT #1, "output 3;SOURce:SAFETy:STEP4:IR:LEVel 800"
PRINT #1, "output 3;SOURce:SAFETy:STEP4:IR:LIMit:HIGH 5000000"

REM Save 4 step test in location 3, label as ACACDCIR
PRINT #1, "output 3;*SAV 3"
PRINT #1, "output 3;MEMory:state:DEFine ACACDCIR,3"

REM Recall ACAC from memory location 1
PRINT #1, "output 3;*RCL 1"

CLOSE : SYSTEM

```

3.4 Printer Interface

An optional Printer Interface is available for the Guardian 1000 Series Instrument. The Printer interface takes the place of the IEEE-488 interface and is factory installed when the unit is ordered. Connection is through the black 25-pin connector labeled 'GPIB' on the rear panel of the Guardian 1000 Series instrument. Figure 3-8 illustrates the Printer interface pin designation.

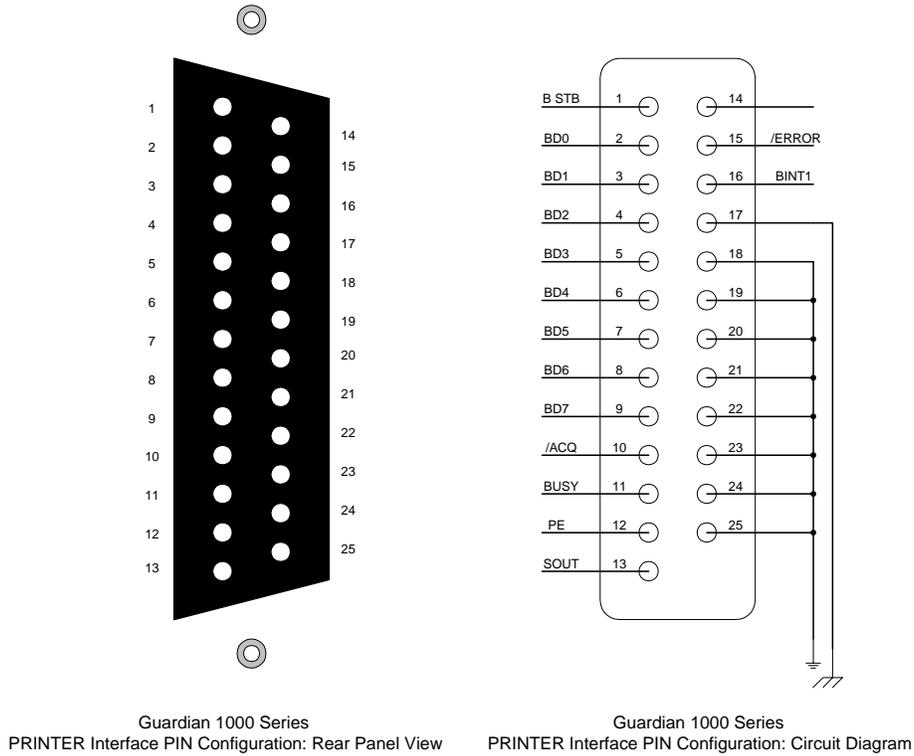

Figure 3-8: Printer Interface Pin Configuration

The following printers have been tested with the G38 printer interface: Epson Stylus Color 440, Epson Stylus Color 460, Epson Stylus Photo 720, Epson LQ570C+ dot matrix, Epson LX-300 and HP DeskJet 648C. Included are two sample printouts: "Print Program" and "Auto Print".

When **Print Program** is selected, the programmed test parameters will print:

```
STEP 1 AC
VOLT: 0.050kV
TIME: 3.0S
HIGH: 0.500mA
LOW : OFF
ARC : OFF
RAMP: OFF
REAL: OFF
      12345678
SCAN: XXXXXXXXX
=====
STEP 2 DC
VOLT: 0.054kV
TIME: 3.0s
HIGH: 0.500mA
LOW : OFF
ARC : OFF
RAMP: OFF
      12345678
SCAN: XXXXXXXXX
=====
STEP 3 IR
VOLT: 0.500kV
TIME: 3.0s
LOW : 1.0MO
HIGH: OFF
RAMP: OFF
      12345678
SCAN: XXXXXXXXX
=====
```

The following will print when **Auto Print**: Pass and Fail and all Print Data options are turned ON:

```
=====
P/N:
L/N:
S/N:
Step-01 AC 0.049kV 0.001mA ----- PASS
Step-02 DC 0.054kV 0.010mA ----- PASS
Step-03 IR 0.501kV 0.8MO ----- LOW
-----FAIL -----
```

3.5 G16 International Power Strip

The Guardian 1000 Series instrument can be connected to the G16 International Power Strip as illustrated in Figure 3-9 for safety testing of many European corded products.

- | | | |
|----------------|-----------------|--------------|
| *Australia | *United Kingdom | *Denmark |
| *North America | *Norway | *Finland |
| *Sweden | *Germany | *Netherlands |
| *Austria | *Switzerland | *Italy |

The three G-16 ground connectors are connected to the Guardian 1000 RTN/LOW terminal. There is a second RTN/LOW terminal on the rear of the Guardian 1000 Series instrument.

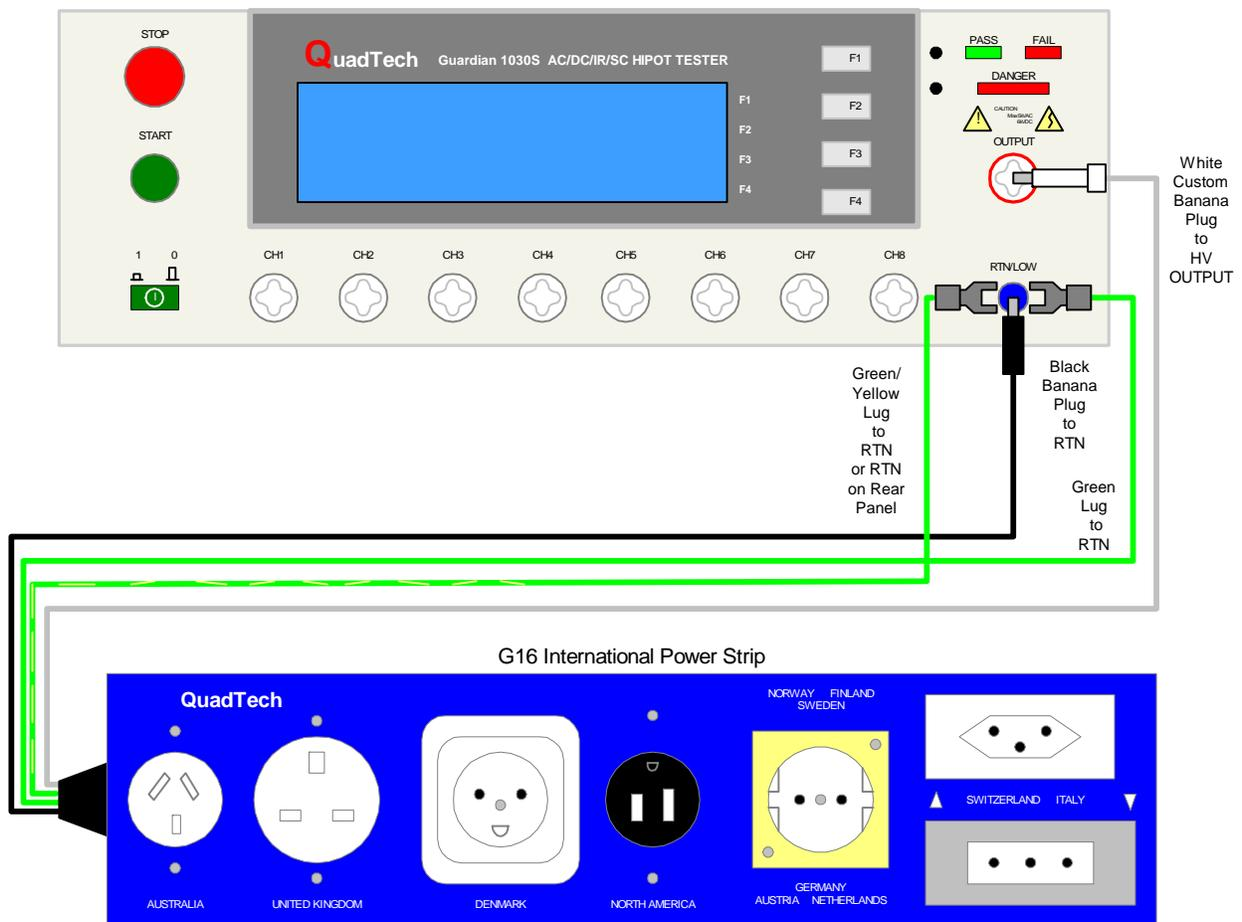

Figure 3-9: G16 International Power Strip Connection to Guardian 1000 Series Instrument

3.6 S07 Power Entry Adaptor Cable

The S07 Power Entry Adaptor Cable is a 3-wire AC inlet receptacle for precise testing of corded products. The S07 cable is connected to the Guardian 1000 Series instrument via a two-lead set. The white custom banana plug is connected to the OUTPUT terminal on the G1000 unit. The black banana plug with retaining bracket is connected to the RTN/LOW terminal on the G1000 unit. Figure 3-10 illustrates this connection of the S07 cable to a Guardian 1030S instrument.

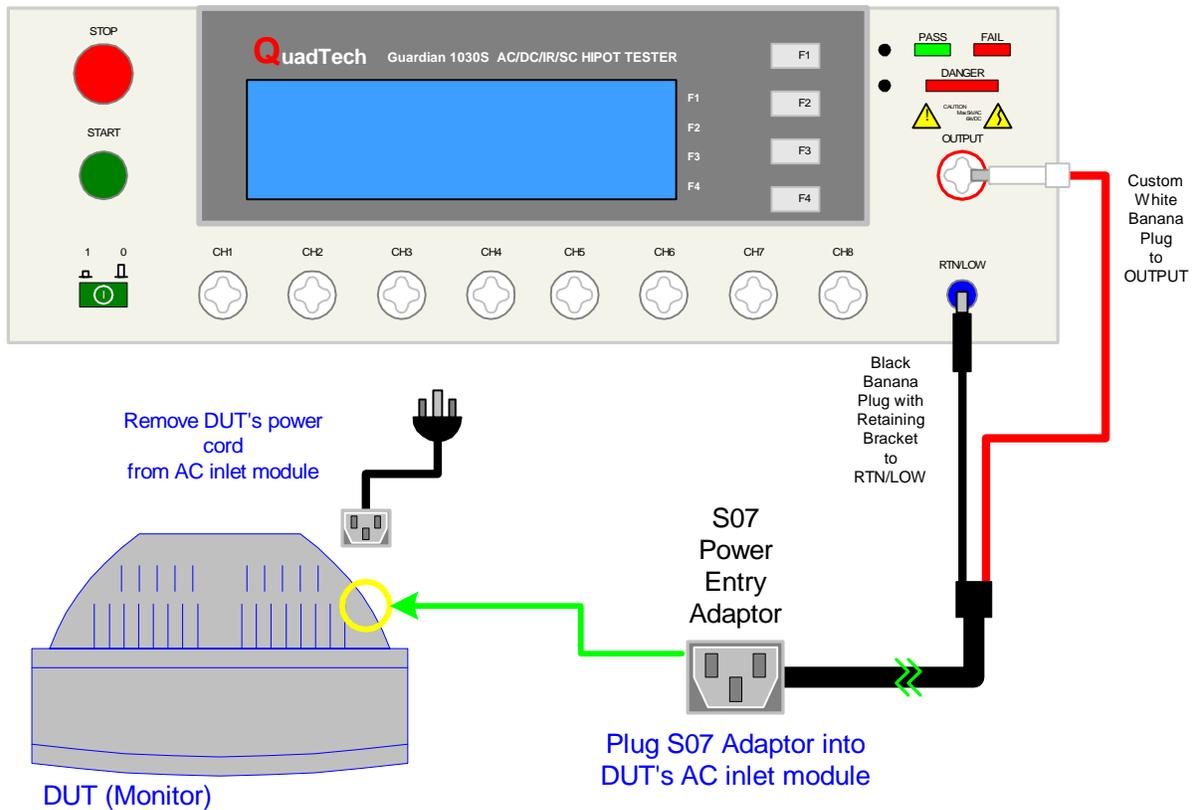

Figure 3-10: S07 Power Entry Adaptor Cable

3.7 S03 Corded Product Adaptor (115V)

The S03 Corded Product Adaptor is a 3-prong electrical outlet box to facilitate testing of corded products. The S03 cable is connected to the Guardian 1000 Series instrument via a two-lead set. The white custom banana plug is connected to the OUTPUT terminal on the G1000 unit. The black banana plug is connected to the RTN/LOW terminal on the G1000 unit. Figure 3-11 illustrates this connection of the S03 cable to a Guardian 1030S instrument.

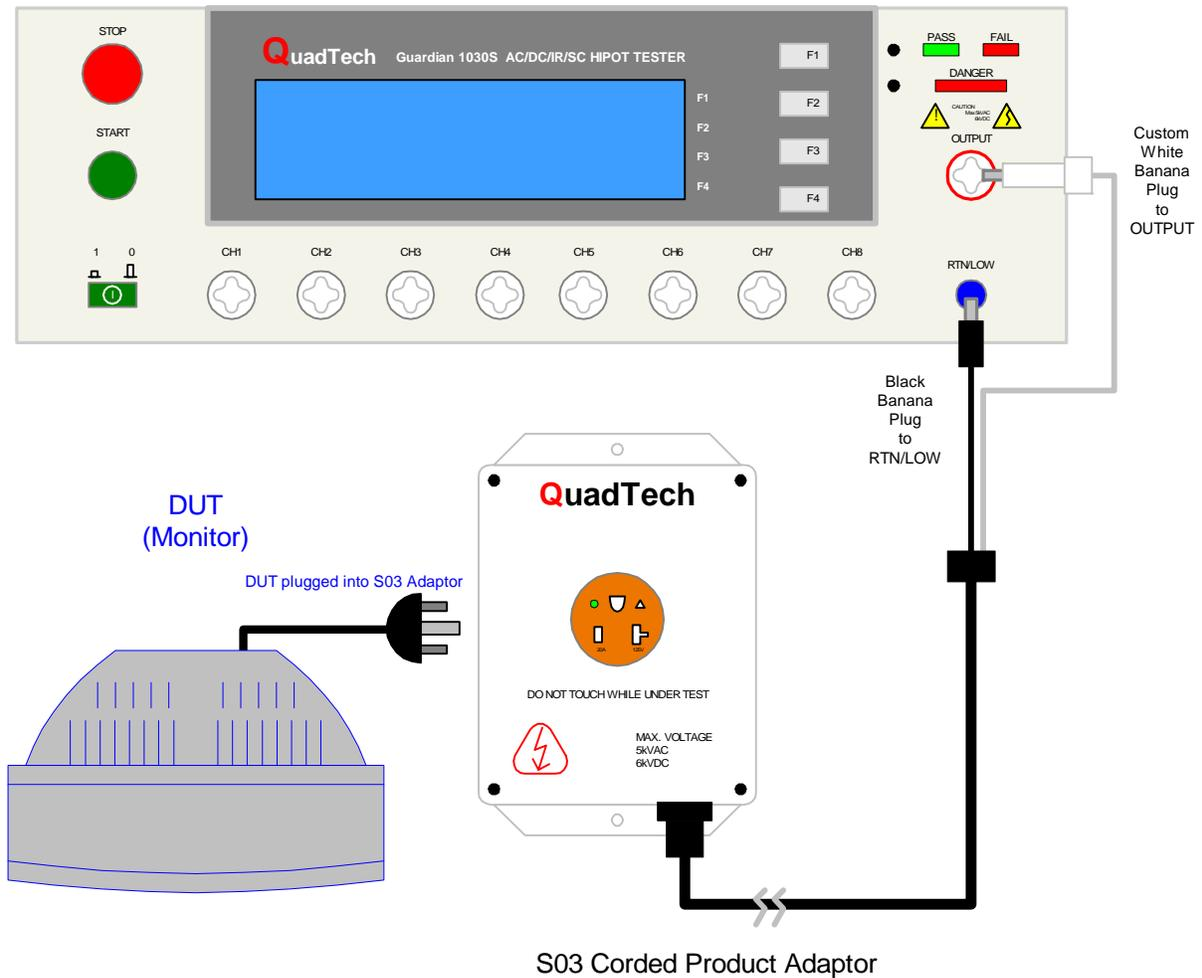

Figure 3-11: S03 Corded Product Adaptor

3.8 S05 Foot Switch

The S05 Foot Switch provides hands-free remote testing capability. The spade leads on the S05 Foot Switch are connected (screwed) to the terminal strip on the rear panel of the Guardian 1000 Series instrument. The white wire/spade connector is screwed to the START terminal and the red wire/spade connector is screwed to the COM terminal. Figure 3-12 illustrates this connection of the S05 Foot Switch to a Guardian 1000 Series instrument.

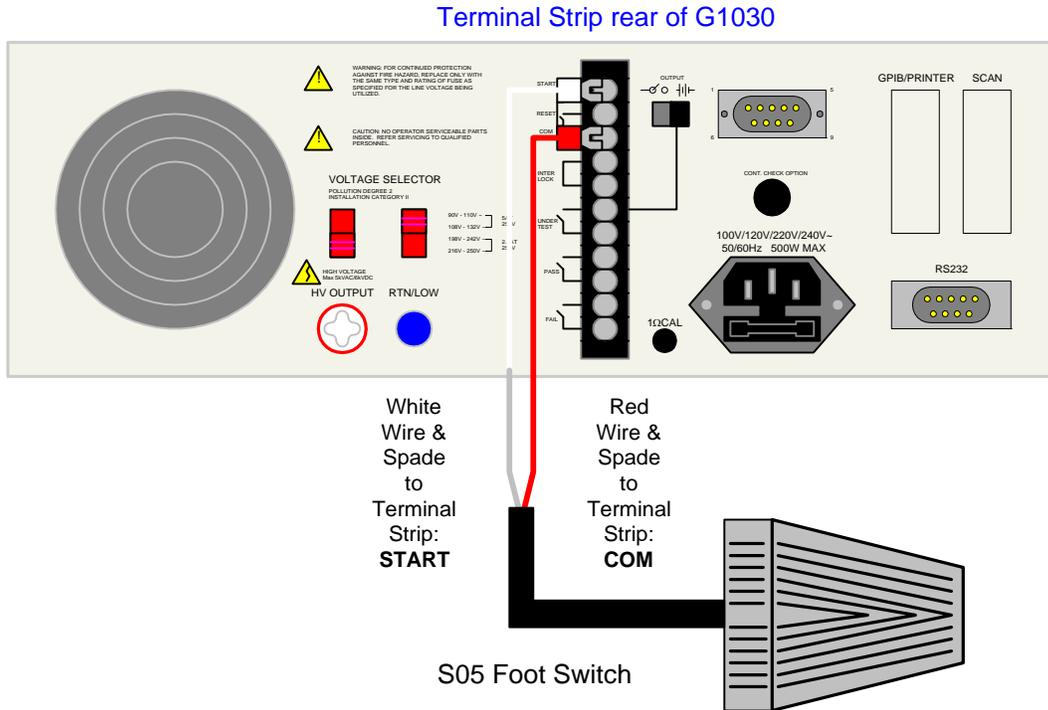

Figure 3-12: S05 Foot Switch

3.9 S08 Gun Probe

The S08 Gun Probe provides fast testing capability with pinpoint control. The custom white banana plug is connected to the OUTPUT terminal on the front panel of the Guardian 1000 Series instrument. Figure 3-13 illustrates this connection of the S08 probe to a Guardian 1030S unit.

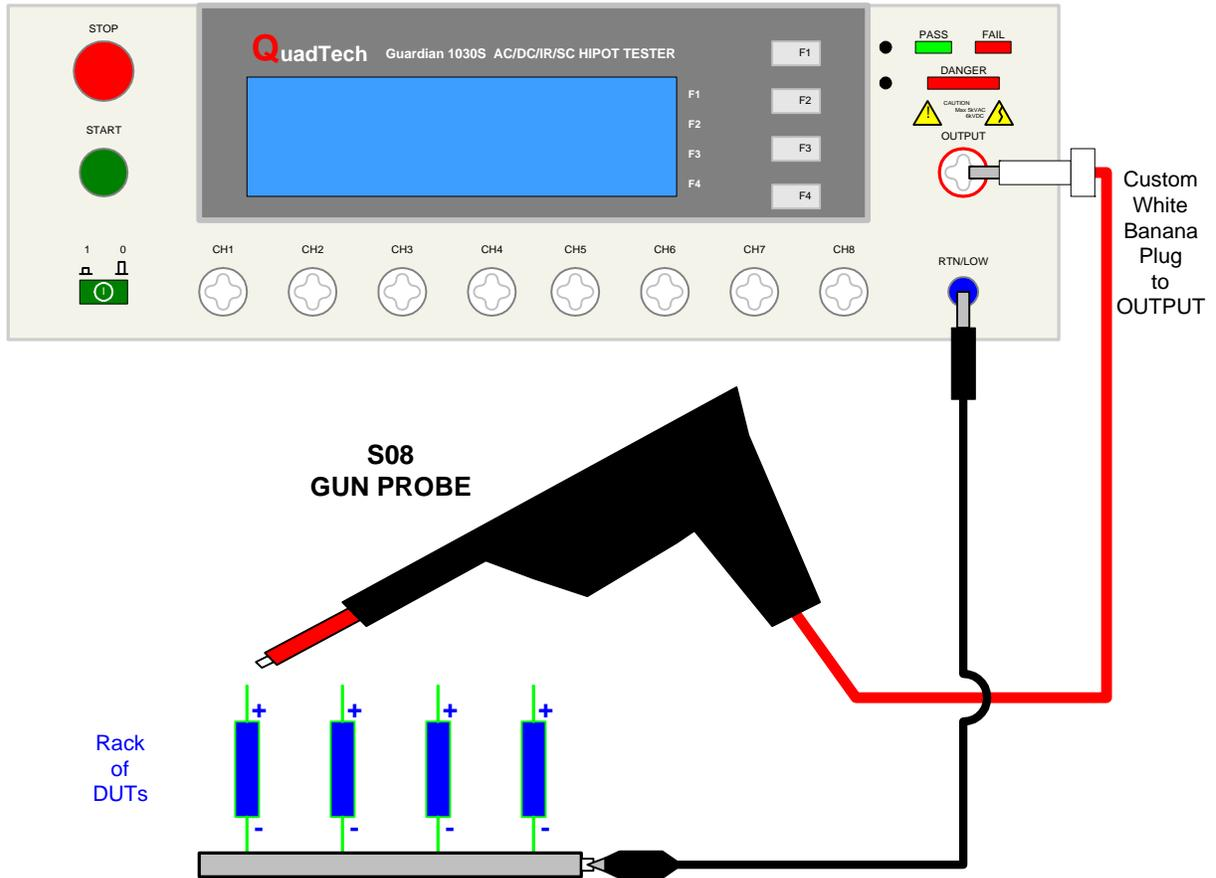

Figure 3-13: S08 Gun Probe

3.10 Guardian 1050 Ground Bond Tester

The Guardian 1000 Series instrument can be connected to the Guardian 1050 Ground Bond Tester for high current ground testing between chassis and power cord ground. The output current is programmable from 1A to 30A AC in 0.01A increments and resistance can be measured over the range 0.1mΩ to 510mΩ. The rear panels of the Guardian 1000 Series instrument and Guardian 1050 instrument are connected via the S15 9-pin interconnection cable. Figure 3-14 illustrates the front panel connections of the two instruments.

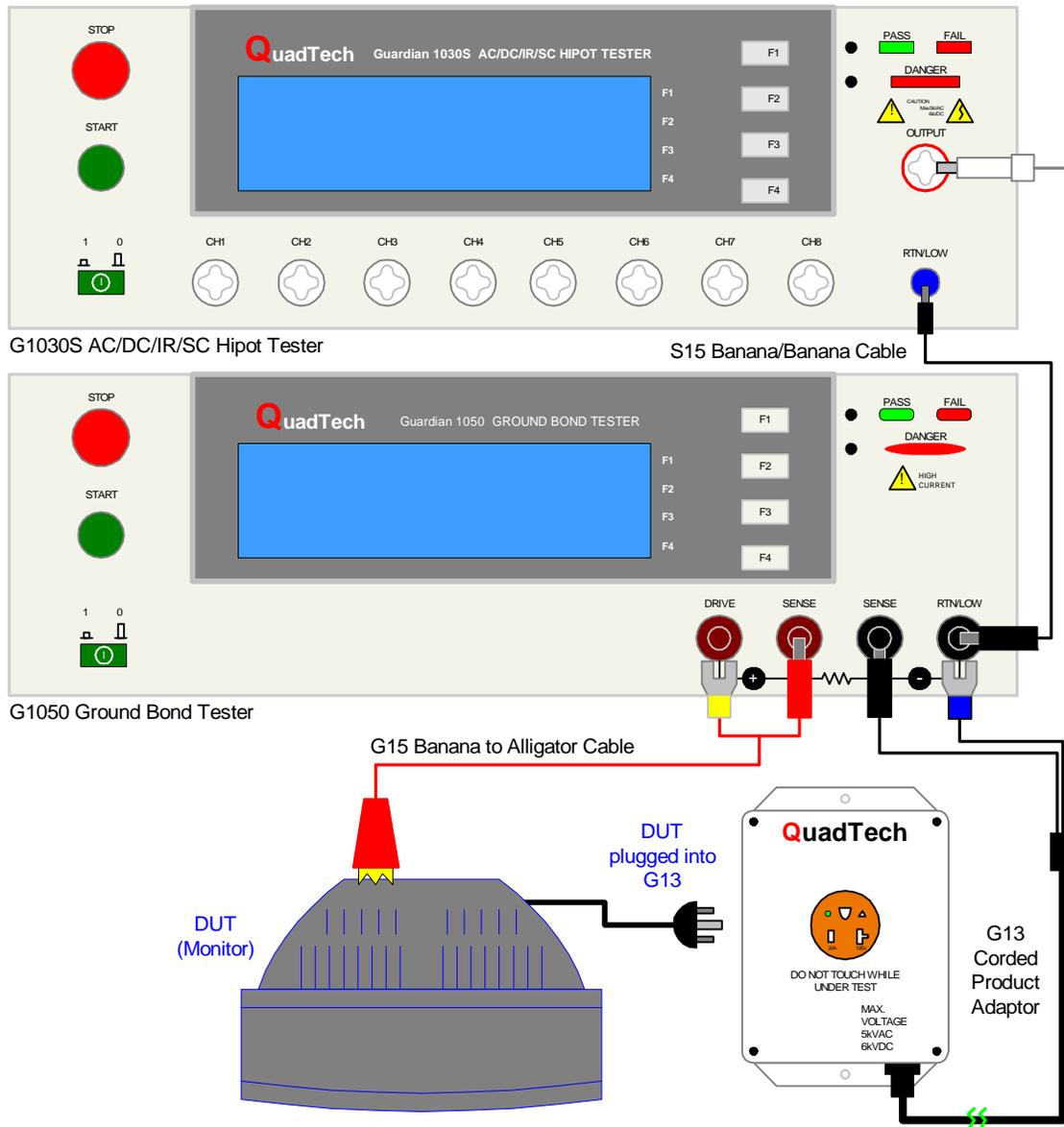

Figure 3-14: Guardian 1030S & Guardian 1050 Connection

Section 4: Service & Calibration

4.1 General

Our warranty (at the front of this manual) attests to the quality of materials and workmanship in our products. If malfunction should be suspected, or other information desired, applications engineers are available for technical assistance. Applications assistance is available in the U.S. by calling (978) 461-2100 and asking for Applications Support. For support outside of the United States please contact your local QuadTech Distributor.

4.2 Instrument Return

Before returning an instrument to QuadTech for service please call our **Customer Care Center (CCC)** at **800-253-1230** for Return Material Authorization (RMA). It will be necessary to include a Purchase Order Number to insure expedient processing, although units found to be in warranty will be repaired at no-charge. For any questions on repair costs or shipping instructions please contact our CCC Department at the afore-mentioned number. To safeguard an instrument during storage and shipping, please use packaging that is adequate to protect it from damage, i.e. equivalent to the original packaging, and mark the box "Delicate Electronic Instrument". Return material should be sent freight prepaid to:

QuadTech, Inc.
5 Clock Tower Place, 210 East
Maynard, Massachusetts 01754

Attention: RMA#

Shipments sent collect cannot be accepted.

4.3 Calibration

Calibration of the Guardian 1000 Series instruments is recommended on an annual basis. If the unit is returned to QuadTech for factory calibration, refer to paragraph 4.2 for RMA and shipping instructions. Using the calibration procedure in paragraph 4.3.1, the Guardian 1000 Series instrument may be calibrated by a qualified service person IF traceable calibration equipment and standards are available. The instrument should be powered up for a minimum of 1 hour prior to calibration to ensure maximum stability.

Table 4-1: Calibration Equipment

Equipment	Parameter	Requirements
AC/DC High Voltage Voltmeter	ACV, DCV, IRV	Measure Range: 0 to 6kV, 0.1% accuracy
AC/DC Current Meter	ACA, RACA, DCA	Measure Range: 0 to 40mA, 0.1% accuracy
1GΩ Resistance Standard	IRR	250V
100MΩ Resistance Standard	IRR	500V
10MΩ Resistance Standard	IRR	500V, 1000V & 1200V
420kΩ Resistance Standard	ACA, DCA, RACA	1200V, 3mA, 50W
50kΩ Resistance Standard	ACA, RACA	1200V, 25mA, 200W
150kΩ Resistance Standard	DCA	1200V, 15mA, 100W

4.3.1 Calibration Parameters

Table 4-2 contains the calibration parameters for the Guardian 1000 Series instruments. All tests points are not required for each of the instruments (1010, 1030 & 1030S).

Table 4-2: Calibration Parameters

TEST		RANGE		CAL. POINT
Voltage Calibration				
CAL	ACV	5kV	OFST	0.100kV
CAL	ACV	5kV	FULL	4.000kV
CAL	DCV	6kV	OFST	0.100kV
CAL	DCV	6kV	FULL	4.000kV
CAL	IR	1kV	OFST	0.100kV
CAL	IR	1kV	FULL	1.000kV
Current Calibration				
CAL	ACA	3mA	OFST	0.120mA
CAL	ACA	3mA	FULL	2.500mA
CAL	ACA	30mA	OFST	2.50mA
CAL	ACA	30mA	FULL	25.00mA
CAL	RACA	3mA	OFST	0.120mA
CAL	RACA	3mA	FULL	2.500mA
CAL	RACA	30mA	OFST	2.50mA
CAL	RACA	30mA	FULL	25.00mA
CAL	DCA	3mA	OFST	0.120mA
CAL	DCA	3mA	FULL	2.500mA
CAL	DCA	10mA	OFST	2.50mA
CAL	DCA	10mA	FULL	8.00mA
WAC and WDC ARCing Calibration				
CAL	AC ARC	30mA	Arc	5.00mA
CAL	DC ARC	10mA	Arc	5.00mA
IR Resistor Mode Calibration				
CAL	IRR Range1	1GΩ	IRR	Range1 to 1GΩ
CAL	IRR Range2	100MΩ	IRR	Range2 to 100MΩ
CAL	IRR Range3	10MΩ	IRR	Range3 to 10MΩ
CAL	IRR Range4	10MΩ	IRR	Range4 to 10MΩ

4.3.2 Enable Calibration

The instrument should be powered up for a minimum of 1 hour prior to calibration to ensure maximum stability. With the Guardian 1000 Series instrument in standby status ([RESET] button previously pressed and no warning lights flashing) remove the Calibration seal over the hole labeled “CAL” on the front panel and push the recessed switch to the IN position.

The unit is in STAND BY status.

Press [F3] = MENU.

Press [F2] = DOWN three times until **CALIBRATION** is highlighted (backlit).

Press [F3] = SELECT to choose calibration function.

Display will prompt for a password.

Press [A] [A] [A] [B] [ENTER]

Cal Step 1: ‘ACV 5kV Offset (100V)’ is displayed on the screen.

NOTE

Figure 4-1 illustrates the password prompt for calibration and the ‘Calibration is OFF’ display. The ‘Calibration is OFF’ display may occur if the CAL recessed switch has **not** been pressed IN prior to entering Calibration function.

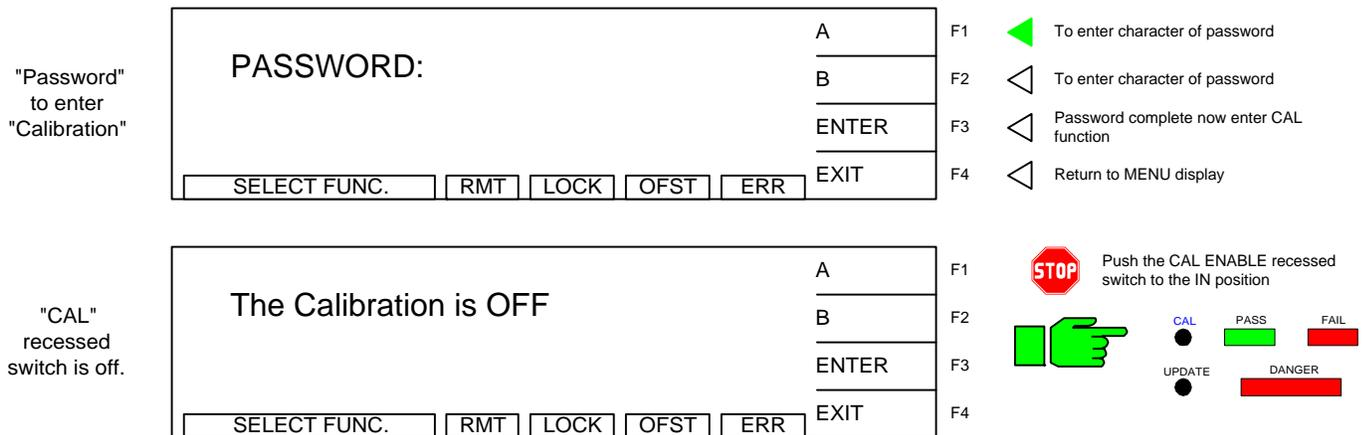

Figure 4-1: Calibration Password Prompt

NOTE

The term ‘G1000’ is used in this Calibration procedure to denote all instruments in the G1000 Series: G1010, G1030 and G1030S.

The DC and IR calibration procedures are applicable to the G1030 and G1030S instruments. ARC calibration is part of the calibration routine but it is not performed on the Guardian 1010, 1030 or 1030S instrument.

4.3.3 AC Voltage Calibration

Connect the OUTPUT terminal of the Guardian1000 Series unit to the input terminal of the AC/DC high voltage meter. Connect the RTN/LOW terminal of the Guardian to the GND terminal of the voltmeter. Set the voltmeter to AC and 2kV range.

Cal Step 1: 'ACV 5kV Offset (100V)'

"ACV Offset"
Display

ACV	5kV	Offset	(500V)	UP	F1	To go to next CAL step.
OUTPUT		READING		DOWN	F2	To go to previous CAL step.
0.500kV		0.000kV		SETUP	F3	To enter ACV OFFSET function
STANDARD: 0.100kV				EXIT	F4	To exit CAL mode & return to MENU.
SELECT FUNC.		RMT	LOCK	OFST	ERR	

1 ● START
To get OFFSET value

3 ● STOP
To accept OFFSET

ACV	5kV	Offset	(100V)	INC	F1	▶ To increase STANDARD value.
OUTPUT		READING		DEC	F2	◀ To decrease STANDARD value.
0.100kV		0.000kV			F3	
STANDARD: 0.100 kV					F4	
STOPPED		RMT	LOCK	OFST	ERR	

Enter voltmeter reading →

Press [STOP] to return instrument to steady state.

Press [START] to get offset value.

Press [F1] = INC or [F2] = DEC until the G1000 display reads the same as the voltmeter.

Press [STOP] to accept reading.

G1000 reverts to "ACV Offset" display (incorporating new cal value).

Press [F1] = UP to go to Cal Step 2: 'ACV 5kV Full (4kV)'. Change voltmeter range to 20kV.

"ACV Full"
Display

ACV	5kV	Full	(4kV)	UP	F1	To go to next CAL step.
OUTPUT		READING		DOWN	F2	To go to previous CAL step.
4.000kV		0.000kV		SETUP	F3	To enter ACV FULL function
STANDARD: 4.000kV				EXIT	F4	To exit CAL mode & return to MENU.
SELECT FUNC.		RMT	LOCK	OFST	ERR	

Press [STOP] to return instrument to steady state.

Press [START] to get full value

Press [F1] = INC or [F2] = DEC until the G1000 display reads the same as the voltmeter.

Press [STOP] to accept reading.

G1000 reverts to "ACV Full" display (incorporating new cal value).

4.3.4 DC Voltage Calibration (DCV)

Change the setting on the Valhalla voltmeter to DC and 2kV range. DC calibration is applicable to the Guardian 1030 and 1030S instruments.

Press [F1] = UP to go to Cal Step 3: 'DCV 6kV Offset (100V)'.

"DCV Offset" Display

DCV	6kV	Offset	(100V)	UP	F1	To go to next CAL step.
OUTPUT		READING		DOWN	F2	To go to previous CAL step.
0.100kV		0.000kV		SETUP	F3	To enter DCV OFFSET function
STANDARD: 0.100kV				EXIT	F4	To exit CAL mode & return to MENU.
SELECT FUNC.	RMT	LOCK	OFST	ERR		

1 **START** To get OFFSET value

3 **STOP** To accept OFFSET

DCV	6kV	Offset	(100V)	INC	F1	To increase OUTPUT value.
OUTPUT		READING		DEC	F2	To decrease OUTPUT value.
0.100kV		0.000kV			F3	
STANDARD: 0.100 kV					F4	
STOPPED	RMT	LOCK	OFST	ERR		

Enter voltmeter reading

Press [STOP] to return instrument to steady state.

Press [START] to get offset value.

Press [F1] = INC or [F2] = DEC until the G1000 display reads the same as the voltmeter.

Press [STOP] to accept reading.

G1000 reverts to "DCV Offset" display (incorporating new cal value).

Press [F1] = UP to go to Cal Step 4: 'DCV 6kV Full (4kV)'. Change voltmeter range to 20kV.

"DCV Full" Display

DCV	6kV	Full	(4kV)	UP	F1	To go to next CAL step.
OUTPUT		READING		DOWN	F2	To go to previous CAL step.
4.000kV		0.000kV		SETUP	F3	To enter DCV FULL function
STANDARD: 4.000kV				EXIT	F4	To exit CAL mode & return to MENU.
SELECT FUNC.	RMT	LOCK	OFST	ERR		

Press [STOP] to return instrument to steady state.

Press [START] to get full value.

Press [F1] = INC or [F2] = DEC until the G1000 display reads the same as the voltmeter.

Press [STOP] to accept reading.

G1000 reverts to "DCV Full" display (incorporating new cal value).

4.3.5 IR Voltage Calibration (IRV)

Keep the setting on the Valhalla voltmeter at DC and 2kV range. IR calibration is applicable to the Guardian 1030 and 1030S instruments.

Press [F1] = UP to go to Cal Step 5: 'IRV 1kV Offset (100V)'.

"IRV Offset" Display

IRV	1kV	Offset	(100V)	UP	F1	To go to next CAL step.
OUTPUT		READING		DOWN	F2	To go to previous CAL step.
0.100kV		0.000kV		SETUP	F3	To enter IRV OFFSET function
STANDARD: 0.100kV				EXIT	F4	To exit CAL mode & return to MENU.
SELECT FUNC.	RMT	LOCK	OFST	ERR		

1 **START** To get OFFSET value

3 **STOP** To accept OFFSET

IRV	1kV	Offset	(100V)	INC	F1	To increase OUTPUT value.
OUTPUT		READING		DEC	F2	To decrease OUTPUT value.
0.100kV		0.000kV			F3	
STANDARD: 0.100 kV					F4	
STOPPED	RMT	LOCK	OFST	ERR		

Enter voltmeter reading

Press [STOP] to return instrument to steady state.

Press [START] to get offset value.

Press [F1] = INC or [F2] = DEC until the G1000 display reads the same as the voltmeter.

Press [STOP] to accept reading.

G1000 reverts to "IRV Offset" display (incorporating new cal value).

Press [F1] = UP to go to Cal Step 6: 'IRV 1kV Full (1kV)'. Change voltmeter range to 20kV.

"IRV Full" Display

IRV	1kV	Full	(1kV)	UP	F1	To go to next CAL step.
OUTPUT		READING		DOWN	F2	To go to previous CAL step.
1.000kV		0.000kV		SETUP	F3	To enter IRV FULL function
STANDARD: 1.000kV				EXIT	F4	To exit CAL mode & return to MENU.
SELECT FUNC.	RMT	LOCK	OFST	ERR		

Press [STOP] to return instrument to steady state.

Press [START] to get full value.

Press [F1] = INC or [F2] = DEC until the G1000 display reads the same as the voltmeter.

Press [STOP] to accept reading.

G1000 reverts to "IRV Full" display (incorporating new cal value).

4.3.6 AC Current Calibration (ACA)

Connect the OUTPUT terminal of the Guardian 1000 Series instrument to a resistance box or resistance standard. Connect an AC/DC current meter in series between the resistance load (box/standard) and the RTN/LOW terminal of the Guardian instrument. Table 4-4 lists the resistance loads necessary for the current calibration steps.

Table 4-4: Resistance Loads

Mode	Step #	Voltage	Calibration Point	Resistance (Load)
ACA	CAL 7	1200 V	0.12mA	10MΩ
ACA	CAL 8	1200 V	2.5mA full	420kΩ
ACA	CAL9	1200 V	2.5mA	420kΩ
ACA	CAL 10	1200 V	25mA	50kΩ
RACA	CAL 11	1200 V	0.12mA	10MΩ
RACA	CAL12	1200V	2.5mA full	420KΩ
RACA	CAL 13	1200 V	2.5mA	420KΩ
RACA	CAL 14	1200 V	25mA	50kΩ
DCA	CAL 15	1200 V	0.12mA	10MΩ
DCA	CAL 16	1200 V	2.5mA full	420kΩ
DCA	CAL 17	1200 V	2.5mA	420kΩ
DCA	CAL 18	1200 V	8mA	150kΩ

Press [F1] = UP to go to Cal Step 7: ‘ACA 3mA Offset (0.12mA)’.

"ACA 3mA Offset" Display	ACA 3mA Offset (0.12mA)	UP	F1	To go to next CAL step.
	OUTPUT READING	DOWN	F2	To go to previous CAL step.
	1.200kV 0.000mA	SETUP	F3	To enter ACA OFFSET function
	STANDARD: 0.120mA	EXIT	F4	To exit CAL mode & return to MENU.
	SELECT FUNC. RMT LOCK OFST ERR			

Press [STOP] to return instrument to steady state.

Press [START] to get offset value.

Press [F1] = INC or [F2] = DEC until the G1000 display reads the same as the current meter.

Press [STOP] to accept reading.

G1000 reverts to “ACA 3mA Offset” display (incorporating the new cal value).

Press [F1] = UP to go to Cal Step 8: 'ACA 3mA Full (2.5mA)'.

"ACA 3mA Full" Display	ACA 3mA Full (2.5mA)	UP	F1	To go to next CAL step.
	OUTPUT READING	DOWN	F2	To go to previous CAL step.
	1.200kV 0.000mA	SETUP	F3	To enter ACA FULL function
	STANDARD: 2.500mA	EXIT	F4	To exit CAL mode & return to MENU.
	SELECT FUNC. RMT LOCK OFST ERR			

Press [STOP] to return instrument to steady state.
 Press [START] to get full value.
 Press [F1] = INC or [F2] = DEC until the G1000 display reads the same as the current meter.
 Press [STOP] to accept reading.
 G1000 reverts to "ACA 3mA Full" display (incorporating the new cal value).

Press [F1] = UP to go to Cal Step 9: 'ACA 30mA Offset (2.5mA)'.

"ACA 30mA Offset" Display	ACA 30mA Offset (2.5mA)	UP	F1	To go to next CAL step.
	OUTPUT READING	DOWN	F2	To go to previous CAL step.
	1.200kV 0.000mA	SETUP	F3	To enter ACA OFFSET function
	STANDARD: 2.500mA	EXIT	F4	To exit CAL mode & return to MENU.
	SELECT FUNC. RMT LOCK OFST ERR			

Press [STOP] to return instrument to steady state.
 Press [START] to get offset value.
 Press [F1] = INC or [F2] = DEC until the G1000 display reads the same as the current meter.
 Press [STOP] to accept reading.
 G1000 reverts to "ACA 30mA Offset" display (incorporating the new cal value).

Press [F1] = UP to go to Cal Step 10: 'ACA 30mA Full (25mA)'.

"ACA 30mA Full" Display	ACA 30mA Full (25mA)	UP	F1	To go to next CAL step.
	OUTPUT READING	DOWN	F2	To go to previous CAL step.
	1.200kV 0.000mA	SETUP	F3	To enter ACA FULL function
	STANDARD: 25.00mA	EXIT	F4	To exit CAL mode & return to MENU.
	SELECT FUNC. RMT LOCK OFST ERR			

Press [STOP] to return instrument to steady state.
 Press [START] to get full value.
 Press [F1] = INC or [F2] = DEC until the G1000 display reads the same as the current meter.
 Press [STOP] to accept reading.
 G1000 reverts to "ACA 30mA Full" display (incorporating the new cal value).

4.3.7 Real AC Current Calibration (RACA)

Connect the OUTPUT terminal of the Guardian 1000 Series instrument to a resistance box or resistance standard. Connect an AC/DC current meter in series between the resistance load (box/standard) and the RTN/LOW terminal of the Guardian instrument.

Press [F1] = UP to go to Cal Step 11: 'RACA 3mA Offset (0.12mA)'.

"RACA 3mA Offset" Display

RACA 3mA Offset (0.12mA)		UP	F1	To go to next CAL step.
OUTPUT	READING	DOWN	F2	To go to previous CAL step.
1.200kV	0.000mA	SETUP	F3	To enter RACA OFFSET function
STANDARD: 0.120mA		EXIT	F4	To exit CAL mode & return to MENU.
SELECT FUNC.	RMT	LOCK	OFST	ERR

Press [STOP] to return instrument to steady state.

Press [START] to get offset value.

Press [F1] = INC or [F2] = DEC until the G1000 display reads the same as the current meter.

Press [STOP] to accept reading.

G1000 reverts to "RACA 3mA Offset" display (incorporating the new cal value).

Press [F1] = UP to go to Cal Step 12: 'RACA 3mA Full (2.5mA)'.

"RACA 3mA Full" Display

RACA 3mA Full (2.5mA)		UP	F1	To go to next CAL step.
OUTPUT	READING	DOWN	F2	To go to previous CAL step.
1.200kV	0.000mA	SETUP	F3	To enter RACA FULL function
STANDARD: 2.500mA		EXIT	F4	To exit CAL mode & return to MENU.
SELECT FUNC.	RMT	LOCK	OFST	ERR

Press [STOP] to return instrument to steady state.

Press [START] to get full value.

Press [F1] = INC or [F2] = DEC until the G1000 display reads the same as the current meter.

Press [STOP] to accept reading.

G1000 reverts to "RACA 3mA Full" display (incorporating the new cal value).

Press [F1] = UP to go to Cal Step 13: ‘RACA 30mA Offset (2.5mA)’.

"RACA 30mA Offset" Display	RACA 30mA Offset (2.5mA)				UP	F1	To go to next CAL step.
	OUTPUT	READING		DOWN	F2	To go to previous CAL step.	
	1.200kV	0.000mA		SETUP	F3	To enter RACA OFFSET function	
	STANDARD: 2.500mA				EXIT	F4	To exit CAL mode & return to MENU.
	SELECT FUNC.	RMT	LOCK	OFST	ERR		

Press [STOP] to return instrument to steady state.

Press [START] to get offset value.

Press [F1] = INC or [F2] = DEC until the G1000 display reads the same as the current meter.

Press [STOP] to accept reading.

G1000 reverts to “RACA 30mA Offset” display (incorporating the new cal value).

Press [F1] = UP to go to Cal Step 14: ‘RACA 30mA Full (25mA)’.

"RACA 30mA Full" Display	RACA 30mA Full (25mA)				UP	F1	To go to next CAL step.
	OUTPUT	READING		DOWN	F2	To go to previous CAL step.	
	1.200kV	0.000mA		SETUP	F3	To enter RACA FULL function	
	STANDARD: 25.00mA				EXIT	F4	To exit CAL mode & return to MENU.
	SELECT FUNC.	RMT	LOCK	OFST	ERR		

Press [STOP] to return instrument to steady state.

Press [START] to get full value.

Press [F1] = INC or [F2] = DEC until the G1000 display reads the same as the current meter.

Press [STOP] to accept reading.

G1000 reverts to “RACA 30mA Full” display (incorporating the new cal value).

4.3.8 DC Current Calibration

Connect the OUTPUT terminal of the Guardian 1000 Series instrument to a resistance box or resistance standard. Connect an AC/DC current meter in series between the resistance load (box/standard) and the RTN/LOW terminal of the Guardian instrument.

Press [F1] = UP to go to Cal Step 15: 'DCA 3mA Offset (0.12mA)'.

"DCA 3mA Offset" Display	DCA 3mA Offset (0.12mA)				UP	F1	To go to next CAL step.
	OUTPUT	READING		DOWN	F2	To go to previous CAL step.	
	1.200kV	0.000mA		SETUP	F3	To enter DCA OFFSET function	
	STANDARD: 0.120mA				EXIT	F4	To exit CAL mode & return to MENU.
	SELECT FUNC.	RMT	LOCK	OFST	ERR		

Press [STOP] to return instrument to steady state.

Press [START] to get offset value.

Press [F1] = INC or [F2] = DEC until the G1000 display reads the same as the current meter.

Press [STOP] to accept reading.

G1000 reverts to "DCA 3mA Offset" display (incorporating the new cal value).

Press [F1] = UP to go to Cal Step 16: 'DCA 3mA Full (2.5mA)'.

"DCA 3mA Full" Display	DCA 3mA Full (2.5mA)				UP	F1	To go to next CAL step.
	OUTPUT	READING		DOWN	F2	To go to previous CAL step.	
	1.200kV	0.000mA		SETUP	F3	To enter DCA FULL function	
	STANDARD: 2.500mA				EXIT	F4	To exit CAL mode & return to MENU.
	SELECT FUNC.	RMT	LOCK	OFST	ERR		

Press [STOP] to return instrument to steady state.

Press [START] to get full value.

Press [F1] = INC or [F2] = DEC until the G1000 display reads the same as the current meter.

Press [STOP] to accept reading.

G1000 reverts to "DCA 3mA Full" display (incorporating the new cal value).

Press [F1] = UP to go to Cal Step 17: 'DCA 10mA Offset (2.5mA)'.

"DCA 10mA Offset" Display	DCA 10mA Offset (2.5mA)				UP	F1	To go to next CAL step.
	OUTPUT	READING		DOWN	F2	To go to previous CAL step.	
	1.200kV	0.000mA		SETUP	F3	To enter DCA OFFSET function	
	STANDARD: 2.500mA				EXIT	F4	To exit CAL mode & return to MENU.
	SELECT FUNC.	RMT	LOCK	OFST	ERR		

Press [STOP] to return instrument to steady state.

Press [START] to get offset value.

Press [F1] = INC or [F2] = DEC until the G1000 display reads the same as the current meter.

Press [STOP] to accept reading.

G1000 reverts to "DCA 15mA Offset" display (incorporating the new cal value).

Press [F1] = UP to go to Cal Step 18: 'DCA 10mA Full (8mA)'.

"DCA 10mA Full" Display	DCA 10mA Full (8mA)				UP	F1	To go to next CAL step.
	OUTPUT	READING		DOWN	F2	To go to previous CAL step.	
	1.200kV	0.000mA		SETUP	F3	To enter DCA FULL function	
	STANDARD: 8.00mA				EXIT	F4	To exit CAL mode & return to MENU.
	SELECT FUNC.	RMT	LOCK	OFST	ERR		

Press [STOP] to return instrument to steady state.

Press [START] to get full value.

Press [F1] = INC or [F2] = DEC until the G1000 display reads the same as the current meter.

Press [STOP] to accept reading.

G1000 reverts to "DCA 15mA Full" display (incorporating the new cal value).

4.3.9 ARC Calibration

NOTE

ARC calibration is part of the calibration routine but it is **not** performed on the Guardian 1010, 1030 or 1030S instrument.

ARC Calibration is set at the factory.

Press [F1] = UP to go to Cal Step 19: ‘AC ARC 30mA (5mA)’. BY-PASS

Press [F1] = UP to go to Cal Step 20: ‘DC ARC 15mA (5mA)’. BY-PASS

4.3.10 IR Resistor Calibration (IRR)

Connect the resistance load (per Table 4-5) between the Guardian instrument’s OUTPUT terminal and RTN/LOW terminal.

Table 4-5: IRR Cal Resistance Loads

IR Resistor Mode Calibration			
STEP #	TEST	LOAD	CAL. POINT
CAL 21	IRR Range1	1GΩ	Range1 to 1GΩ
CAL 22	IRR Range2	100MΩ	Range2 to 100MΩ
CAL 23	IRR Range3	10MΩ	Range3 to 10MΩ
CAL 24	IRR Range4	10MΩ	Range4 to 10MΩ

Press [F1] = UP to go to Cal Step 21: ‘IRR Range1 (1GΩ)’.

"IRR Range1" Display	IRR Range1 (1GΩ)	UP	F1	To go to next CAL step.
	OUTPUT READING	DOWN	F2	To go to previous CAL step.
	0.250kV 0.000MΩ	SETUP	F3	To enter IRR Range1 function
	STANDARD: 1000MΩ	EXIT	F4	To exit CAL mode & return to MENU.
	SELECT FUNC. RMT LOCK OFST ERR			

Press [STOP] to return instrument to steady state.

Press [START] to get range1 value.

Press [F1] = INC or [F2] = DEC until the G1000 display reads the same as certified load value.

Press [STOP] to accept reading.

G1000 reverts to “IRR Range1” display (incorporating the new cal value).

Press [F1] = UP to go to Cal Step 22: 'IRR Range2 (100MΩ)'.

"IRR Range2" Display	IRR Range2 (100MΩ)	UP	F1	To go to next CAL step.
	OUTPUT READING	DOWN	F2	To go to previous CAL step.
	0.500kV 0.000MΩ	SETUP	F3	To enter IRR Range2 function
	STANDARD: 100.0MΩ	EXIT	F4	To exit CAL mode & return to MENU.
	SELECT FUNC. RMT LOCK OFST ERR			

Press [STOP] to return instrument to steady state.

Press [START] to get range2 value.

Press [F1] = INC or [F2] = DEC until the G1000 display reads the same as certified load value.

Press [STOP] to accept reading.

G1000 reverts to "IRR Range2" display (incorporating the new cal value).

Press [F1] = UP to go to Cal Step 23: 'IRR Range3 (10MΩ)'.

"IRR Range3" Display	IRR Range3 (10MΩ)	UP	F1	To go to next CAL step.
	OUTPUT READING	DOWN	F2	To go to previous CAL step.
	0.500kV 0.000MΩ	SETUP	F3	To enter IRR Range3 function
	STANDARD: 10.00MΩ	EXIT	F4	To exit CAL mode & return to MENU.
	SELECT FUNC. RMT LOCK OFST ERR			

Press [STOP] to return instrument to steady state.

Press [START] to get range3 value.

Press [F1] = INC or [F2] = DEC until the G1000 display reads the same as certified load value.

Press [STOP] to accept reading.

G1000 reverts to "IRR Range3" display (incorporating the new cal value).

Press [F1] = UP to go to Cal Step 24: 'IRR Range4 (10MΩ)'.

"IRR Range4" Display	IRR Range4 (10MΩ)	UP	F1	To go to next CAL step.
	OUTPUT READING	DOWN	F2	To go to previous CAL step.
	1.000kV 0.000MΩ	SETUP	F3	To enter IRR Range4 function
	STANDARD: 10.00MΩ	EXIT	F4	To exit CAL mode & return to MENU.
	SELECT FUNC. RMT LOCK OFST ERR			

Press [STOP] to return instrument to steady state.

Press [START] to get range4 value.

Press [F1] = INC or [F2] = DEC until the G1000 display reads the same as certified load value.

Press [STOP] to accept reading.

G1000 reverts to "IRR Range4" display (incorporating the new cal value).

4.3.11 Finalize Calibration

When all calibration steps are complete:

Press [F4] = EXIT

Release the [CAL] enable switch to the **OUT** position using the tip of a small screwdriver.

1. Press [F2] = DOWN three times.
2. Press [F3] = SELECT
3. Display prompts: 'PASSWORD'.
4. Press [A] [A] [A] [A] [ENTER]
5. Display prompts: 'Calibration is OFF' or 'Calibration is ON'.
6. If 'Calibration is OFF', repeat steps 1, 2, 3 & 4 until display reads 'Calibration is ON'.